

ZEXEL

FOREWORD

This service manual has been prepared for the purpose of assisting service personnel in providing efficient and correct service and maintenance on the RAD-K type mechanical governor for diesel engines.

This manual includes procedures for adjustment, disassembly and assembly of components.

The contents of this manual, including illustrations, drawings, and specifications, are the latest available at the time of printing.

The right is reserved to make changes in specifications and procedures at any time without notice.



FEATURES

The RAD type mechanical governor is a minimum-maximum speed governor; a more developed version of the conventional RSVD type mechanical governor. This advanced version makes it possible to change the floating lever ratio transmitting the flyweight motion to the control rack.

The RAD type mechanical governor is designed to reduce the floating lever ratio during low-speed control, to easily move the control rack with only a small centrifugal force generated in the flyweight, and therefore provide a stable engine speed. When the engine speed exceeds the rated engine speed, the governor operates to increase the lever ratio and therefore decrease speed droop.

The RAD(K) governor is mainly used in automobiles, and mounted on PE-A and AD type injection pumps.

The RAD-K type mechanical governor incorporates a torque control device. This device functions, in the full load-high speed range of the engine, to increase engine output by increasing fuel injection quantity, and, in the full load-low speed range, to reduce the emission of black smoke discharged from the engine, by decreasing fuel injection quantity.



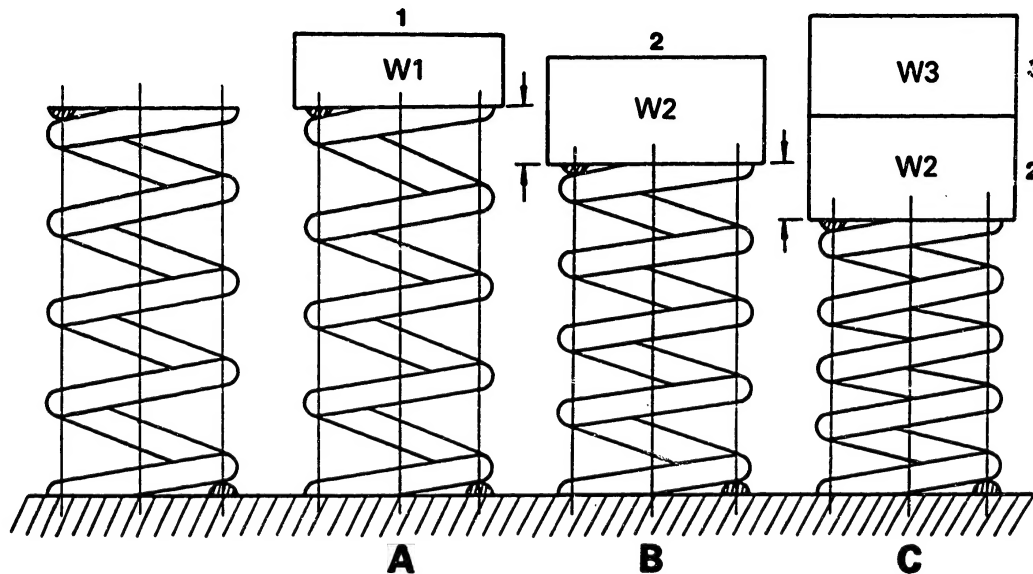

Fig. 1 Spring and weight

1 = weight W1

2 = weight W2

3 = weight W3

PRINCIPLES OF OPERATION

If a weight less than the spring force is placed on the spring, as shown in Fig. 1-A, the spring will not be compressed: that is, its length remains the same. If the weight is greater than the spring force, the spring will be compressed to the position shown in Fig. 1-B, where the spring force is balanced with the weight. If an extra weight is added to the first, the spring will be further compressed as shown in Fig. 1-C, to support the two weights. If one of the two weights is then removed, the spring will return to the position B in Fig. 1 to support the remaining weight.

A3

Principles of operation
RAD-K governor



A4

Principles of operation
RAD-K governor

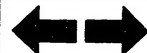

Principles of operation (continuation)

When the spring is compressed to support the weight(s) it is said that the spring and weight(s) are balanced.

A governor in which this balance between spring and weight is utilized is called a mechanical governor. The mechanical governor controls the engine speed by using the balance between the spring force, and the flyweights' centrifugal force resulting from the two flyweights mounted on the shaft moving outward through rotation of the shaft.

A5

Principles of operation

RAD-K governor



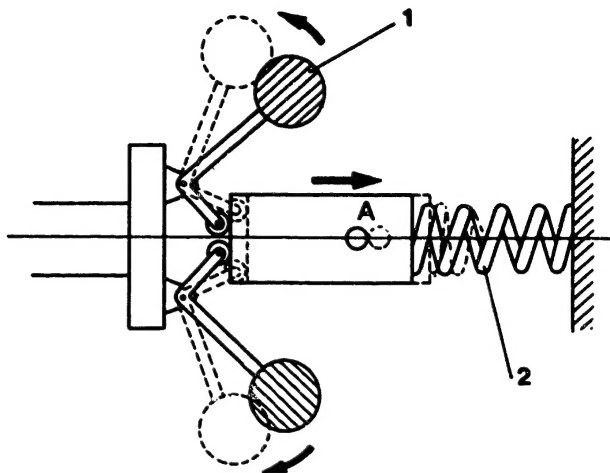

Fig. 2 Balance between spring and centrifugal force

1 = flyweight

2 = spring

The centrifugal force of the flyweights depends upon the number of revolutions. As the number of revolutions of the flyweights increases, the centrifugal force increases, the flyweights move outward from the solid-line state in Fig. 2, and the spring is compressed. Point A then moves to the right, and the centrifugal force and the spring force are balanced at the dotted-line positions.



**Balance between spring and centrifugal force
(continuation)**

If the number of revolutions of the flyweights decreases, the centrifugal force decreases, and the flyweights are brought inward by the spring force. Point A then moves to the left and stops at a position where the smaller centrifugal force and the spring force are balanced.



Fuel injection quantity adjustment Operation

The injection pump controls the fuel injection quantity through the following operation. The control rack rotates the pinion, and the control sleeve fixed to the pinion rotates the plunger. The plunger is set in such a way that the fuel injection quantity decreases when the control rack is drawn toward the governor, and the fuel injection quantity increases when the control rack is moved in the opposite direction. The governor is connected to the control rack to reduce the fuel injection quantity to the engine, and to prevent the engine speed from increasing, by moving the control rack in the "fuel-decrease" direction when the engine speed exceeds the specified value.



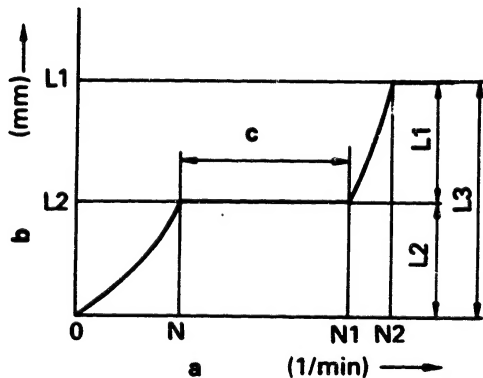

Fig. 3 Relationships between flyweight lift and pump speed

- a = pump speed (rpm)
- b = control rack position
- c = non-controlled zone

RAD type governor

The functions performed by the RAD governor will be explained on the basis of flyweight lift characteristics (Fig. 3) and the performance chart of the governor (Fig. 4).

Fig. 3 explains the relationships between pump speed and flyweight lift.



RAD type governor (continuation)

The flyweight performs two operations; high-speed control and low-speed control. During high-speed control, it operates to draw the control rack in the "fuel-decrease" direction, so as to prevent the engine from exceeding the rated maximum speed by maintaining balance with the governor spring. During low-speed control, it operates to stabilize idling speed by maintaining balance with the idling spring.

These relationships can be illustrated, in terms of flyweight lift, as high-speed lift (L1) for high-speed control and low-speed lift (L2) for low-speed control.

The high-speed lift L1 and the low-speed lift L2 combined constitute the total lift L3 of the flyweight.

The relationships between flyweight lift and pump speed can be explained in the performance chart of the governor (Fig. 4) as follows:



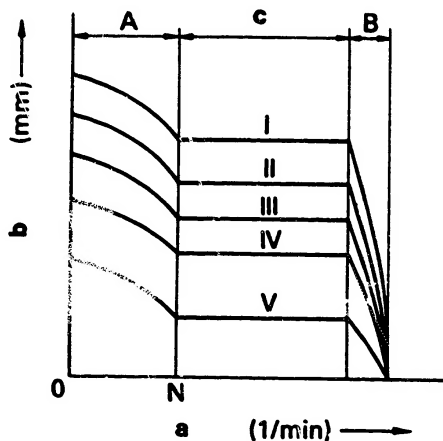

Fig. 4 Performance chart of a minimum-maximum speed governor

a = pump speed (rpm)
 b = control rack position
 c = non-controlled zone

A: low-speed controlled zone
 B: high-speed controlled zone

RAD type governor

The travel of the control rack in zone A corresponds to the movement of the flyweight at low-speed as shown in Fig. 3, while the travel of the control rack in zone B corresponds to the movement of the flyweight at high-speed.



RAD type governor (continuation)

The intermediate zone between A and B corresponds to the position, generally called "non-controlled zone", where the control rack does not travel even when pump speed increases, and where the flyweight lift as shown in Fig. 3 is zero.

I, II, III, etc. in Fig. 4 represent control characteristics obtained when only the position of the control rack is changed by altering the angle of depression of the load control lever. For example, as the control lever is depressed in the "fuel-increase" direction, the position of the control rack will shift horizontally as from IV to III, II, I.



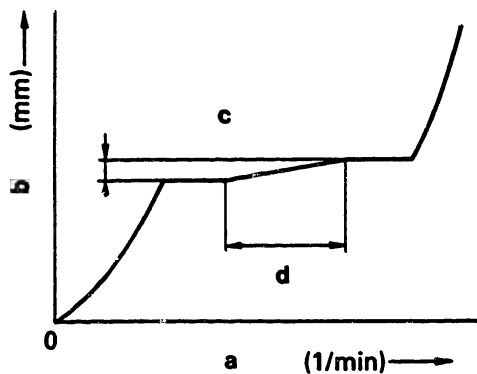

Fig. 5 Relationships between flyweight lift and pump speed

- a = pump speed (rpm)
- b = flyweight lift
- c = torque control lift
- d = torque control operating zone

RAD type governor

Unlike the RAD type governor, the RAD-K type governor can move, in the non-controlled zone, the control rack in the "fuel-increase" direction. In this case, the performance chart of the governor will be as shown in Fig. 6. To this end, a torque control device and an "increase" lever are attached to the tension lever and the guide lever, respectively.

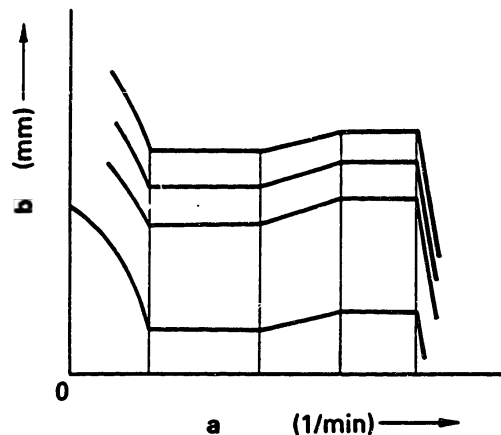
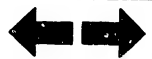

Fig. 6 Governor performance chart

- a = pump speed (rpm)
- b = control rack position



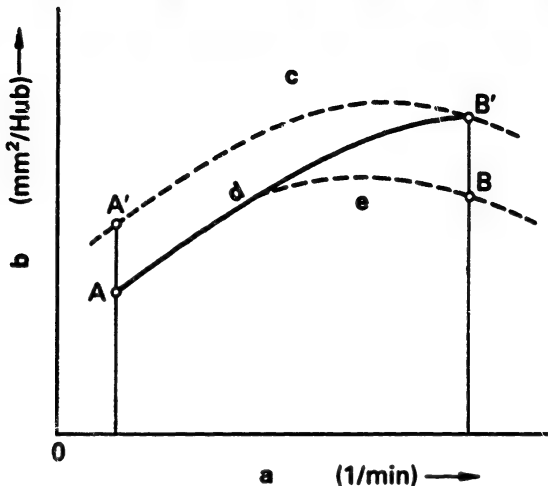

Fig. 7 Torque control device

- a = engine speed (rpm)
- b = injection quantity per stroke (mm^3/st)
- c = large injection quantity setting
- d = fuel requirement curve
- e = small injection quantity setting

RAD-K type governor

An injection pump for a direct-injection engine describes, as the pump speed increases, fuel injection quantity curves as shown by the broken lines in Fig. 7 even with the control rack in the same position.



Torque control device
RAD-K type governor (continuation)

Therefore, if full load is set at point A, injection quantity will reach point B as engine speed increases, thus limiting engine output. If full load is set at point B' in order to obtain optimum output, black smoke will be emitted at point A'.

The torque control device operates in such a way that in the low-speed zone full load setting may be made at point A without black smoke being emitted, and that in the high-speed zone as large an output as possible may be obtained. This injection quantity is shown by the solid lines in Fig. 7.

This torque control device is mounted behind the idling spring attached to the tension lever, with specifications varying according to the application and range of engine speed intended.



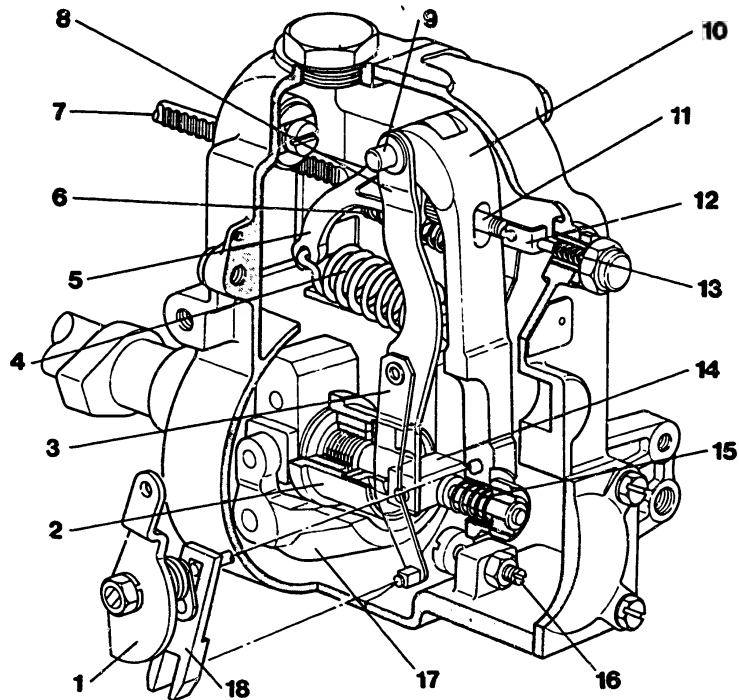

Fig. 8 Construction drawing of RAD type governor

- 1 = Load control lever
- 2 = Sleeve
- 3 = Floating lever
- 4 = Governor spring
- 5 = Speed setting lever
- 6 = Start spring

- 7 = Control rack
- 8 = Guide lever
- 9 = Tension lever shaft
- 10 = Tension spring
- 11 = Speed adjusting screw
- 12 = Link

- 13 = Damper spring
- 14 = Shifter
- 15 = Idling spring
- 16 = Stroke adjusting screw
- 17 = Flyweight
- 18 = Supporting lever

CONSTRUCTION

RAD type governor

Fig. 8 shows the construction of an RAD type mechanical governor.

The RAD type mechanical governor has a flyweight attached to the camshaft of the injection pump. When this flyweight opens outward the flyweight slider pushes the sleeve in the axial direction. A shifter is connected to the sleeve bearings. This shifter travels only in the axial direction, being incorporated with the guide lever suspended from the tension lever shaft. A floating lever is mounted on a shaft, in the middle of the guide lever. A block is mounted on the floating lever pin.

This block fits the groove in the lower part of the supporting lever. The supporting lever is fitted with a control lever, through an eccentric shaft, so that the floating lever may be actuated by operating the control lever.

The control rack is connected to the upper part of the floating lever by way of a link. The start spring is attached to the upper part of the floating lever, and to the spring eye of the governor housing. The tension lever is suspended from the tension lever shaft to which the guide lever is attached.



RAD type governor (continuation)

Between the tension lever and the speed setting lever, the governor spring is engaged, and determines setting force by means of the speed adjusting screw attached to the speed setting lever. Accordingly, within the normal speed range (the speed beyond governor control), the lower end of the tension lever is always in contact with the stroke adjusting screw. A pin is press fitted to the lower portion of the tension lever, which in turn fits the groove located in the upper portion of the supporting lever. It is therefore possible at high-speed control to increase lever ratios through the linking of the tension lever, the supporting lever and the floating lever. An idling spring is built into the lower portion of the tension lever for idling-speed control.

A 20

Construction

RAD-K governor

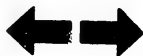

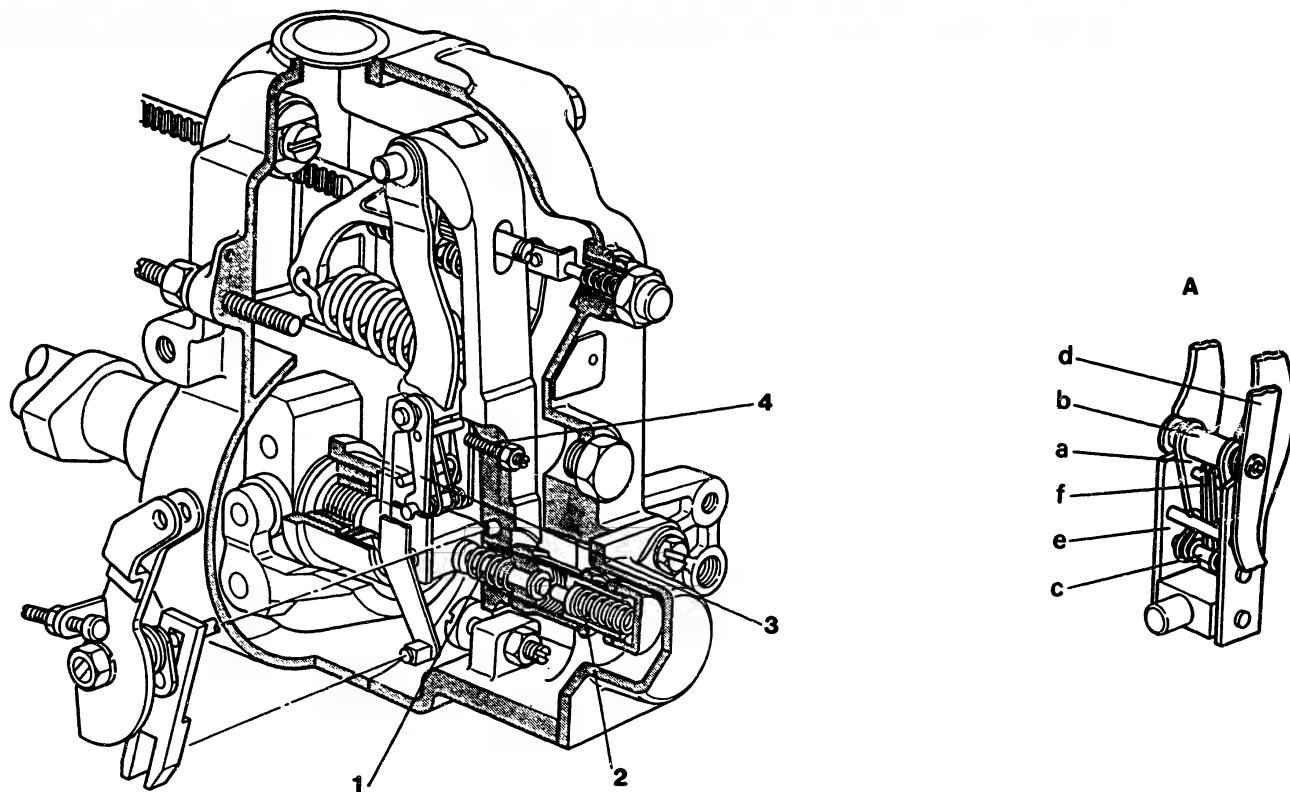

Fig. 9 Construction drawing of RAD-K type governor

- 1 = Idling spring
- 2 = Torque control spring
- 3 = Increase lever
- 4 = Adjusting screw 181/3

A = Detail: Increase lever

A21

Construction
RAD-K governor



A22

Construction
RAD-K governor



RAD-K type governor

The construction of an RAD-K type governor is shown in Fig. 9. Its construction is basically the same as that of the RAD type governor, except for the addition of the torque control device and the "increase" lever (a). One end of the increase lever is connected to the guide lever (e) by pin (c), and the other end to the floating lever (d). Pins (b) and (c) are provided with "cancel" springs (f) which permit the use of the increase lever when torque control is desired. The tension lever is provided with an adjusting screw (181/3) to adjust the torque control stroke. The tip of this bolt is in contact with pin (b) of the increase lever, and pushes the lever when torque control is actuated. The idling spring and the torque control spring are fitted to the tension lever in the same way as on the conventional type of governor.

A23

Construction

RAD-K governor



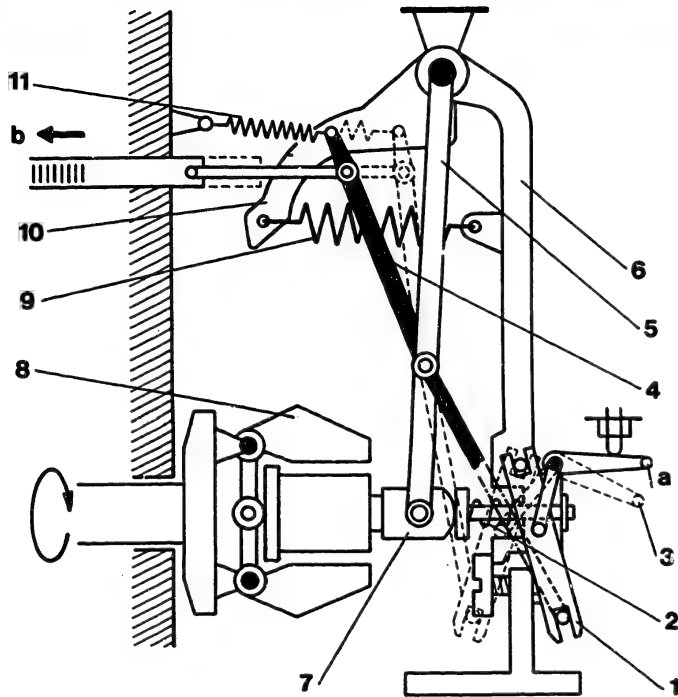

Fig. 10 Engine starting and idling control

- 1 = Supporting lever
- 2 = Idling spring
- 3 = Idling position
- 4 = Floating lever
- 5 = Guide lever
- 6 = Tension lever
- 7 = Shifter
- 8 = Flyweight

OPERATION

RAD type governor

- 9 = Governor spring
- 10 = Speed setting lever
- 11 = Start spring
- a = Full-load position of load control lever
- b = Fuel increase direction

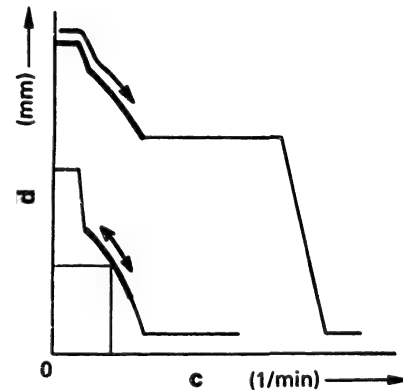

c = Pump speed (rpm)
d = Control rack position

A24	Operation	➔
	RAD-K governor	

A25	Operation	↔
	RAD-K governor	

Engine starting and idling control

RAD type governor - operation

When the engine is not in operation the flyweight is closed, being acted upon by the governor spring, idling spring and start spring. In this state the load control lever and speed setting lever are fully depressed in the "fuel-increase" direction and the control rack is advanced to the position where maximum fuel-injection quantity may be provided at engine starting. If a rack limiter is provided, the control rack will travel until it strikes the stopper of the limiter.

Once the engine starts and the load control lever is returned to the idling position, the flyweight's centrifugal force will increase or decrease according to variations in engine speed. Thus the flyweight provides, within the idling speed range, a small amount of centrifugal force so that its centrifugal force is kept in balance with the force of the idling spring and the start spring, therefore maintaining the control rack in a fixed position. The engine is therefore in a condition permitting smooth idling operation.

However, with any change in engine speed, the centrifugal force of the flyweight will change accordingly. This change is transmitted to the shifter. The shifter functions to transmit this change through the guide lever and the floating lever to the control rack, which adjusts fuel injection quantity so as to stabilize the engine at the determined idling speed. (Fig. 10)



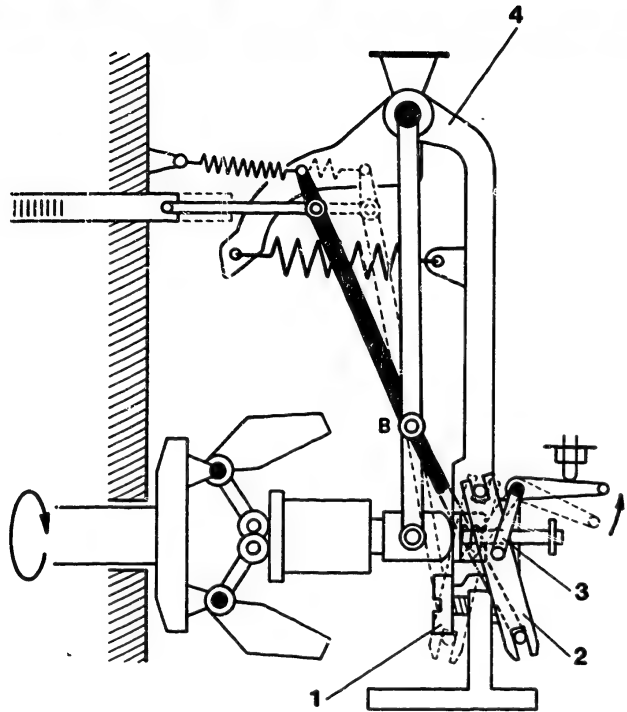
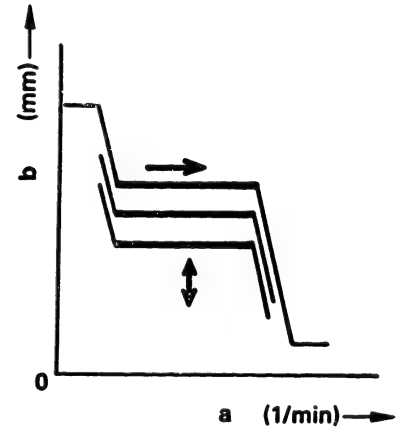

Fig. 11 Normal service operation

RAD type governor

- 1 = Stroke adjusting screw
- 2 = Supporting lever
- 3 = Eccentric lever
- 4 = Tension lever



- a = Pump speed (rpm)
- b = Control rack position

When the load control lever moves in the "fuel-increase" direction (to the position where it strikes the full load stopper bolt), the floating lever is rotated, by means of the eccentric shaft connected to the load control lever, about the common supporting point B and pushes the control rack in the "fuel-increase" direction to increase engine speed.

When engine speed exceeds the idling control area, the idling spring will be compressed until the shifter directly strikes the tension lever.

A27

Operation

RAD-K governor



A28

Operation

RAD-K governor



Normal service operation (continuation)

RAD type governor

The tension lever then strikes the stroke adjusting screw through the force of the governor spring.

However, the centrifugal force generated by the flyweight proves, within the normal service speed range, too small to move the tension lever.

Since this also prevents the common supporting point B from moving, operation of the load control level is transmitted to the control rack to increase or decrease the fuel injection quantity. (Fig. 11)

B1

Operation
RAD-K governor



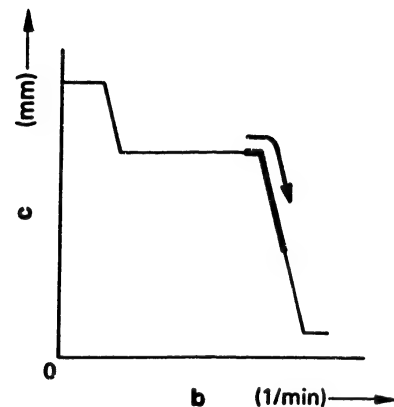
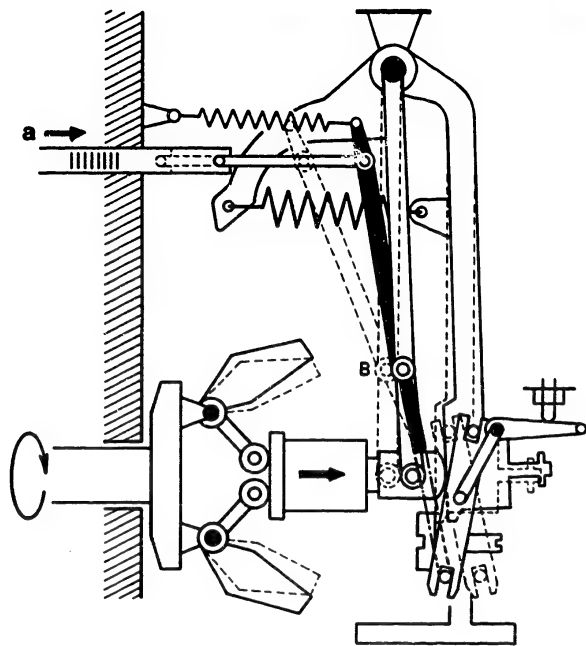

Fig. 12 Maximum speed control

RAD type governor

a = Fuel decrease direction

b = Pump speed (rpm)

c = Control rack position

When the engine attains its specified maximum speed due to changes in engine load, the centrifugal force of the flyweight overcomes the set force of the governor spring, causing the flyweight to open. This causes the shifter and the tension lever to move to the right-hand side (Fig. 12). The control rack will then be drawn in the "fuel-decrease" direction, to prevent the engine from exceeding the specified maximum speed.

B2

Operation
RAD-K governor



B3

Operation
RAD-K governor

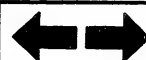

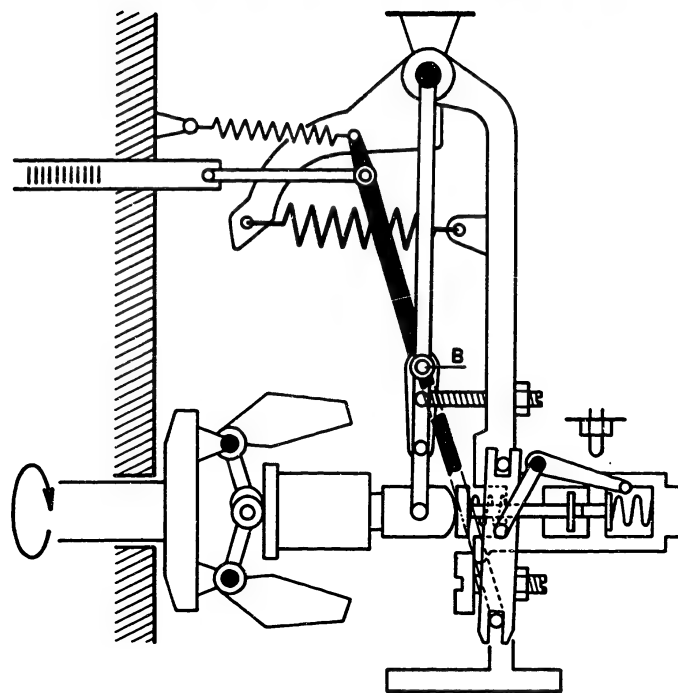
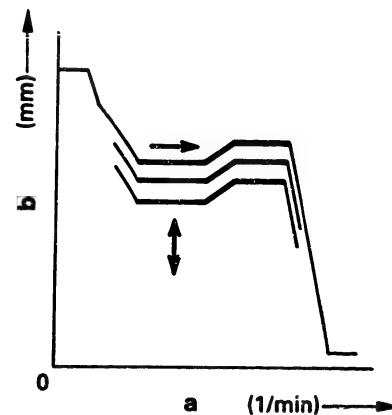

Fig. 13 Normal service operation

RAD-K type governor



a = Pump speed (rpm)
b = Control rack position

Engine starting and idling control

The above description of RAD type governor operation also applies to the RAD-K type governor.

When the control lever moves in the "fuel-increase" direction the supporting lever pivots around the pin in the tension lever. At the same time, the floating lever pivots around the common supporting point B, moving the control rack in the "fuel-increase" direction to increase engine speed.

B4

Operation
RAD-K governor



B5

Operation
RAD-K governor



Normal service operation (continuation)

RAD-K type governor

As the engine speed increases, the idling spring push rod strikes the torque control spring push rod, and remains in that position until the centrifugal force of the flyweight overcomes the torque control spring force. At that time, the tip of the adjusting screw attached to the tension lever makes contact with the face of the increase lever pin.

B6

Operation

RAD-K governor



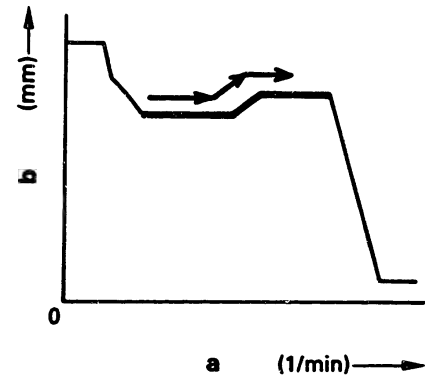
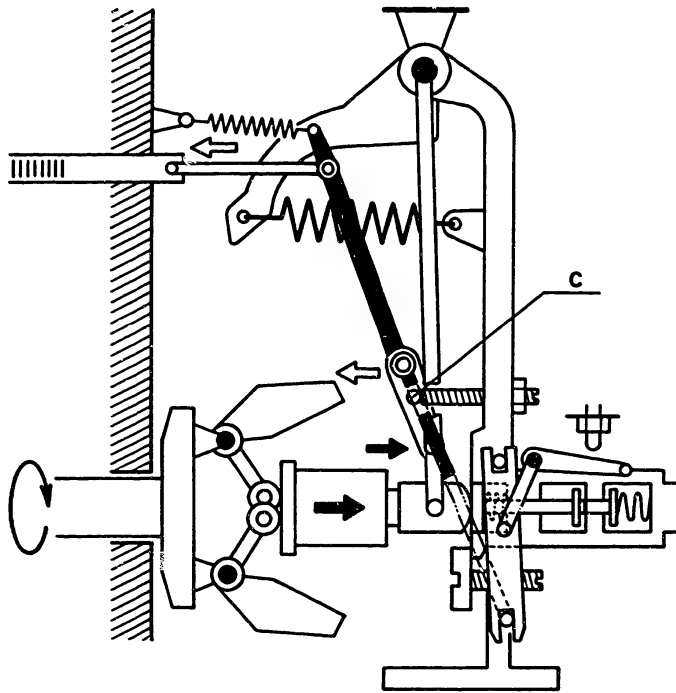

Fig. 14 Torque control device operation

a = Pump speed (rpm)
b = Control rack position

When the engine speed increases further, until the centrifugal force of the flyweight overcomes the torque control spring force, the shifter will travel in the direction of the arrow \rightarrow , compressing the torque control spring. The guide lever will also travel in the direction of the arrow \leftarrow .

Movement of the increase lever in the "increase" direction is however, restricted by the adjusting screw.

B7

Operation
RAD-K governor

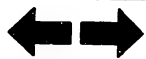

B8

Operation
RAD-K governor



**Torque control device operation
(continuation)**

As a result, the connecting pin between the guide lever and the increase lever moves, with the contact point "c" as the supporting point, in the direction of the arrow \Rightarrow , while the connecting pin between the floating lever and guide lever moves in the direction of the arrow \Rightarrow . This will cause the control rack to travel in the "fuel-increase" direction and actuate torque control. (Fig. 14)



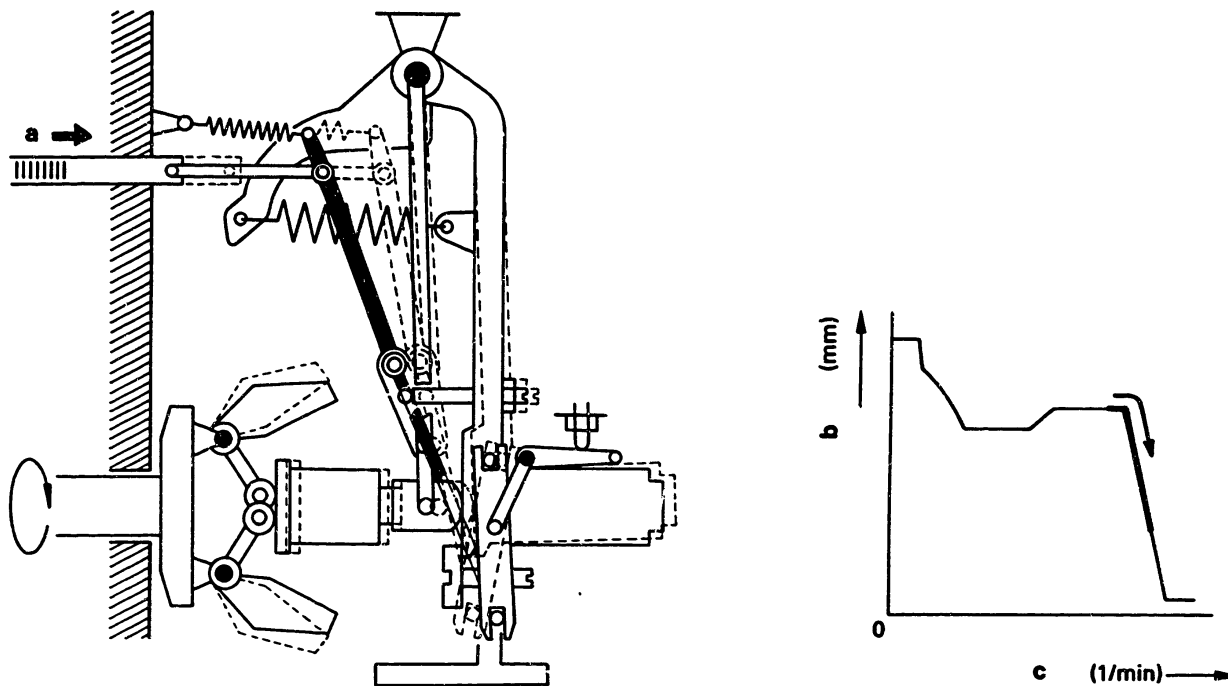

Fig. 15 Maximum speed control

a = Fuel decrease direction

b = Control rack position
c = Pump speed (rpm)

When the engine attains the prescribed maximum speed due to changes in the load applied to the engine, the centrifugal force of the flyweight overcomes the set force of the governor spring, causing the flyweight to start opening. This movement causes the shifter and the tension lever to draw the control rack in the "fuel-decrease" direction, as was done with the RAD type governor, to keep the engine from exceeding the prescribed maximum speed. (Fig. 15)

B10

Operation
RAD-K governor

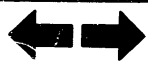

B11

Operation
RAD-K governor



DISASSEMBLY

Preparation

- Keep the workshop and work bench clean.
- Before disassembly clean completely the outside surface of the governor.
- Extract lubricating oil from the cam chamber and the governor chamber.
- Arrange disassembled component parts in order on the work bench.
- The figures parenthesized after the description of each component part refer to its key number given in Fig. 113.

B12

Disassembly
RAD-K governor



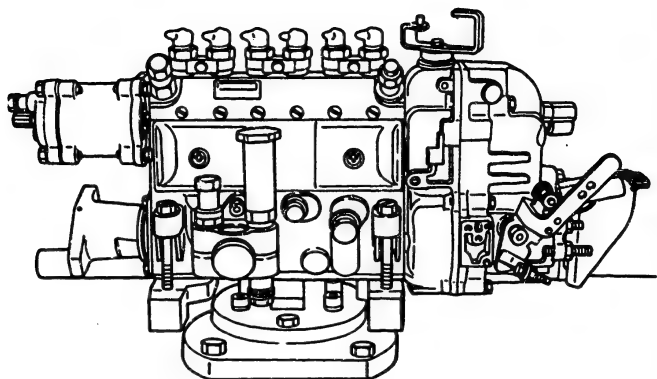

Fig. 16 Attaching the injection pump

1. Attach the injection pump assembly to the universal vise (KDEP 2919).

B13

Disassembly
RAD-K governor



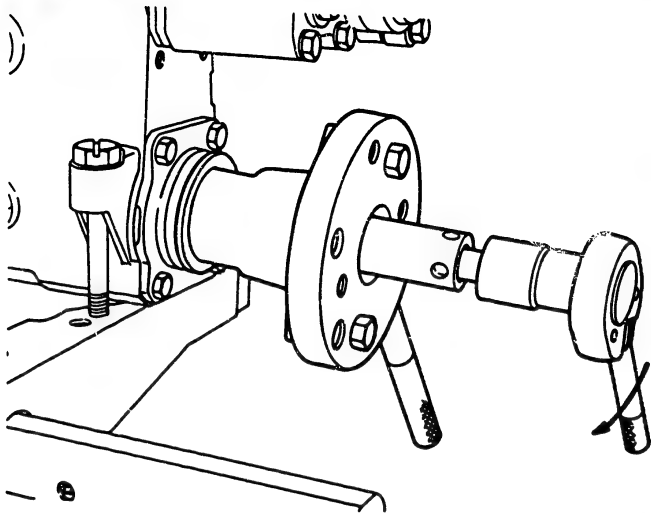

Fig. 17 Removal of pump side coupling

2. Remove the feed pump and pump side coupling. (Fig. 17)
3. Attach the coupling for disassembly and reassembly to the pump camshaft.



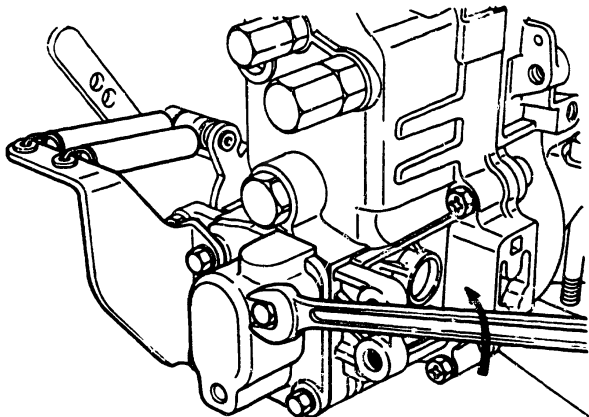

Fig. 18 Removal of bolts

- 4. Remove the four bolts (82, 83, 84 and 86). (Fig. 18).**
- 5. Remove the cover, two springs (195) and bracket (255) together.**



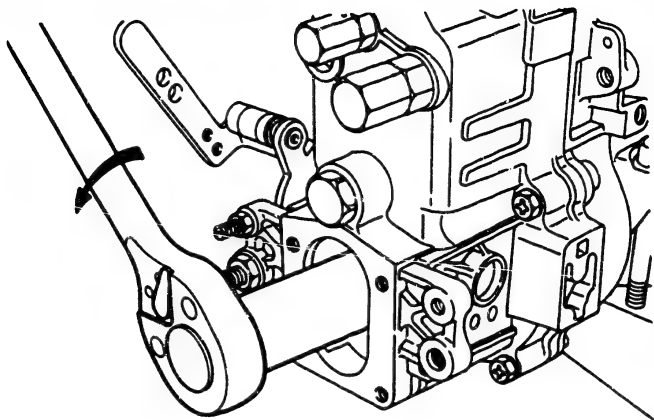

Fig. 19 Removal of torque control spring assembly

6. Using a socket wrench, loosen the lock nut (141) and remove the torque control spring assembly (331).

Note: This applies only to RAD-K type governor.



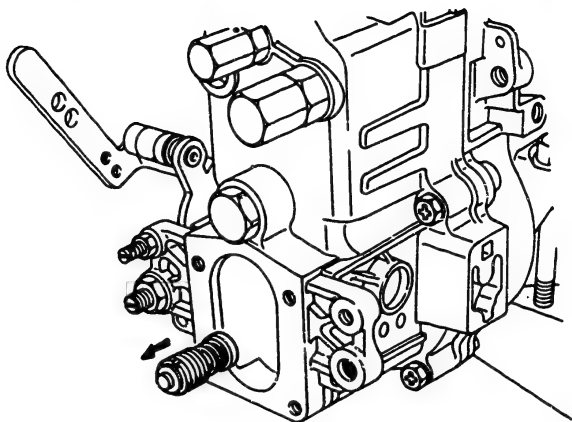

Fig. 20 Removal of idling spring assembly

7. Loosen the guide screw (332) then remove the idling spring assembly (140).



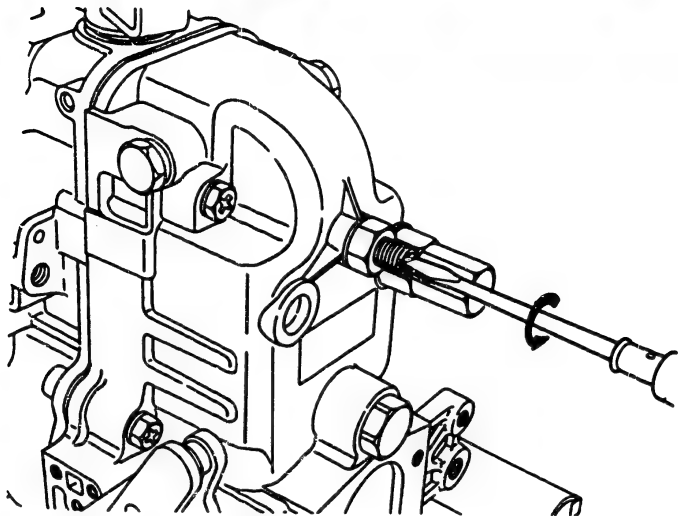

Fig. 21 Loosening speed adjusting screw

8. Remove the cap nut (46), and loosen the lock nut (45). Then loosen the speed adjusting screw (44), to release the governor spring. (Fig. 21)



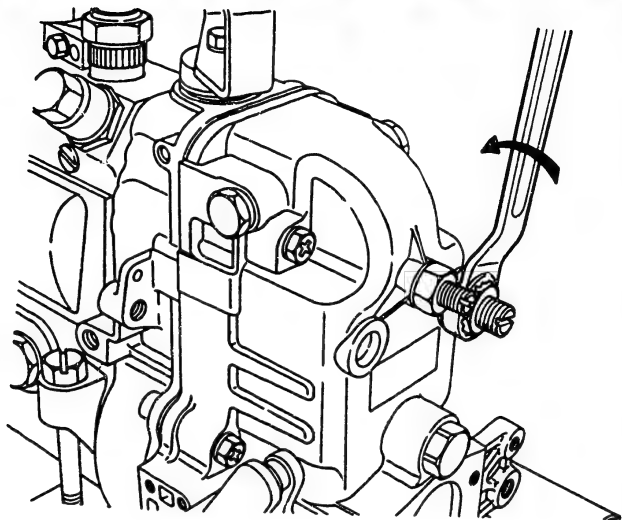

Fig. 22 Loosening locknut

9. Remove the cap nut (223).
10. Loosen the locknut (221) and remove the damper spring assembly (220). (Fig. 22)



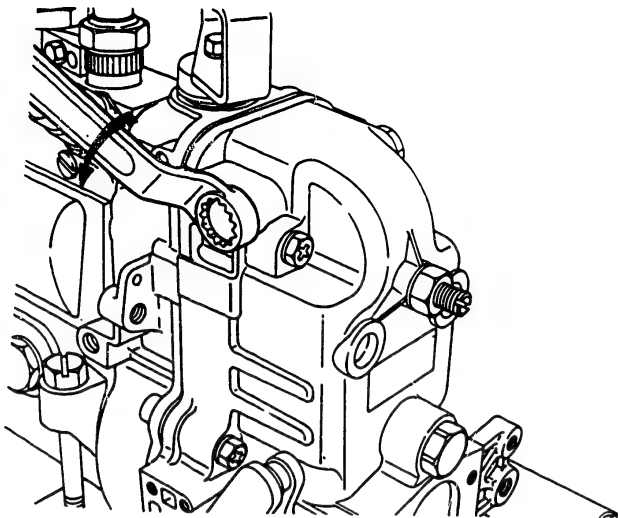
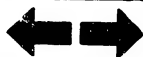

Fig. 23 Removal of plugs

11. Remove the two tension lever shaft plugs (47).



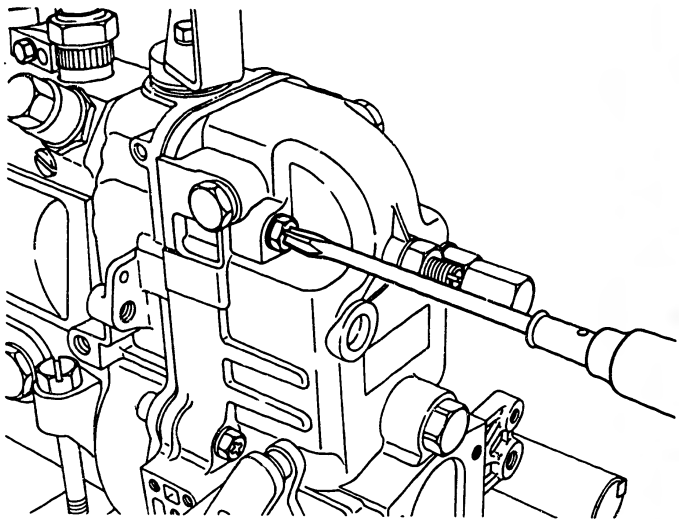

Fig. 24 Removal of bolts

12. Remove the six bolts (51 and 52) to separate governor cover (35) from governor housing (1).

B21

Disassembly
RAD-K governor



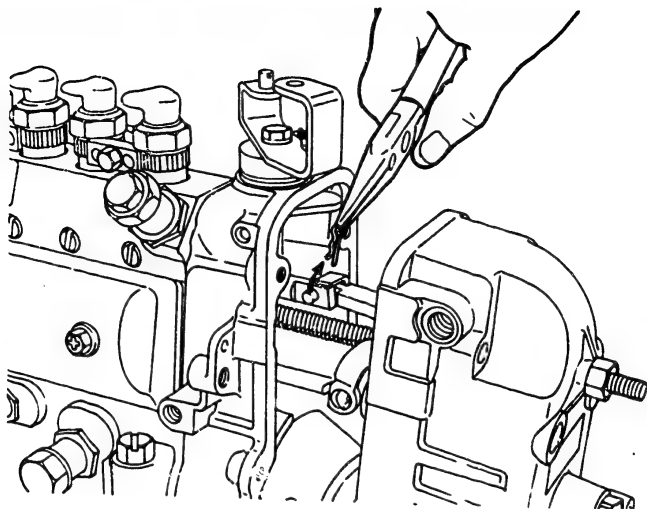

Fig. 25 Drawing out snap-pin

13. Remove the link (174) from the control rack.
To do this, draw out the snap-pin (176) with long-nose pliers as shown in Fig. 25. Then, slide the governor cover horizontally, so that the link pin may be removed from the control rack.



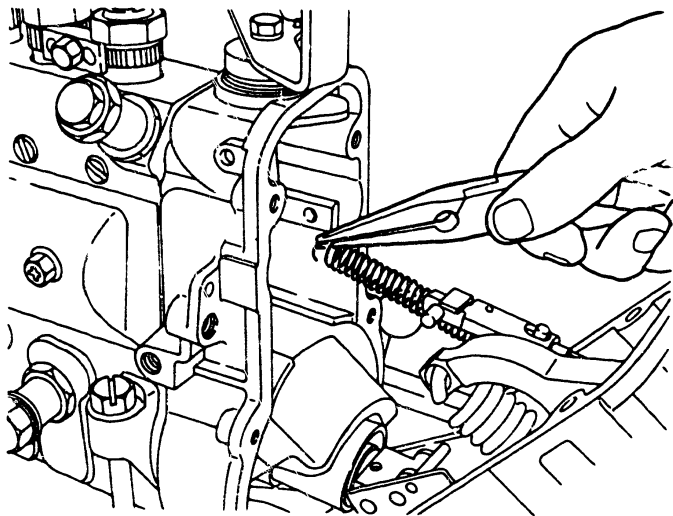
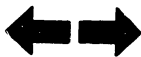

Fig. 26 Removal of start spring

14. Using long-nose pliers, remove the start spring (132) from the spring eye (9).



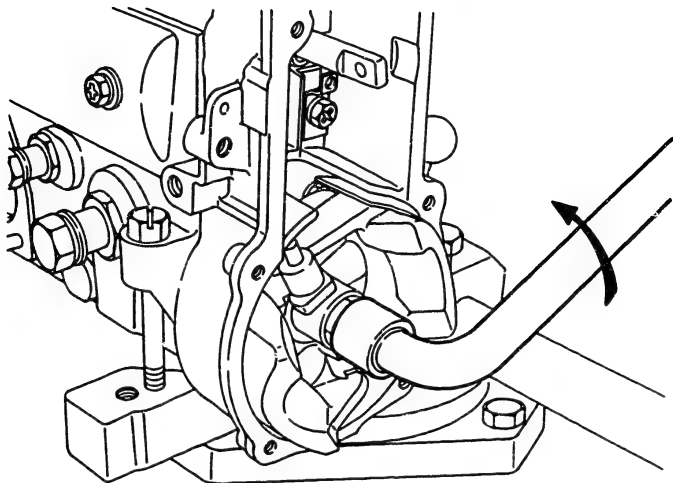

Fig. 27 Removal of roundnut

15. Using a wrench (KDEP 2626), remove the roundnut (103).



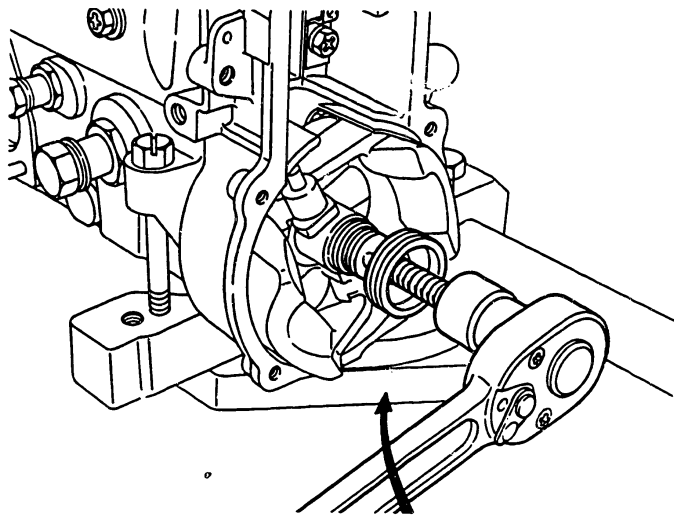

Fig. 28 Removal of flyweight

16. Using an extractor (KDEP 2872), remove the flyweight assembly (100) from the pump camshaft.



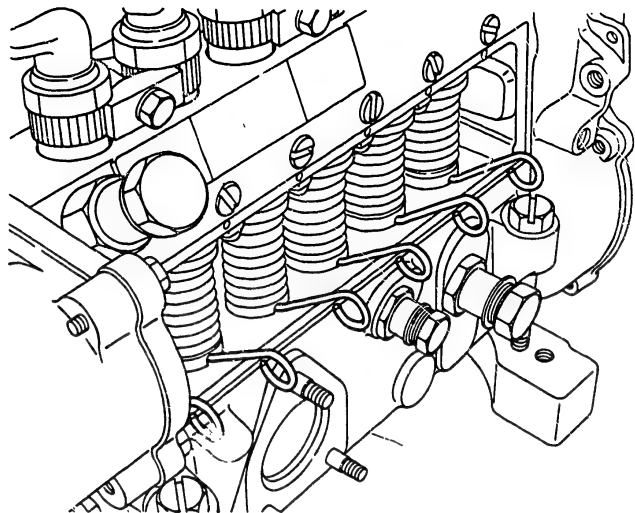

Fig. 29 Inserting tappet holder

17. Remove the pump cover plate, and using the special wrench (KDEP 2906), turn the camshaft. When the tappet reaches top dead center, insert the tappet holder (KDEP 2608) into the tappet's hole, so that the tappet can be released from the cam.



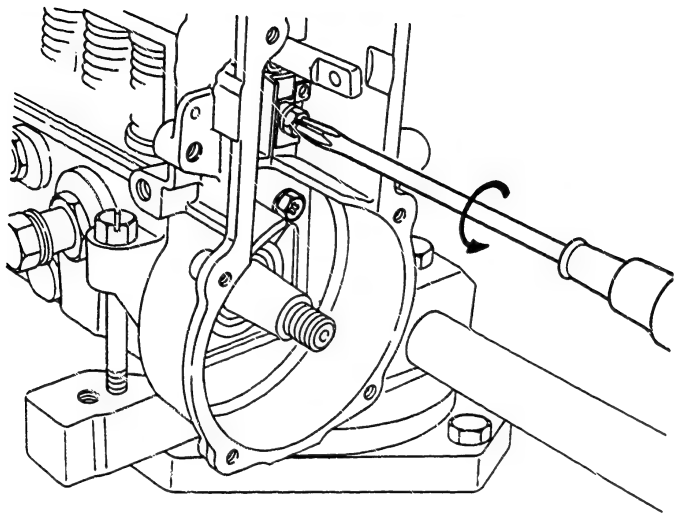

Fig. 30 Removal of bolts

18. Remove the six bolts (5 x SW10 mm and 1 x SW12 mm), together with the spring eye (9).



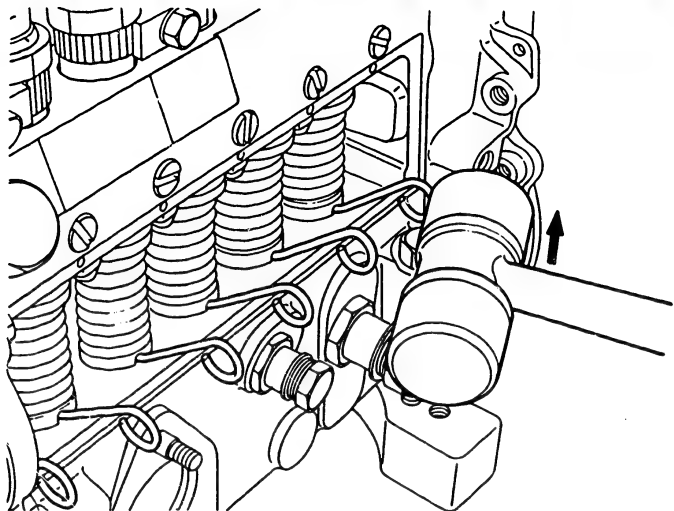

Fig. 31 Removal of governor housing

19. Give governor housing a light tap with a mallet to separate the governor housing(1) from the pump housing.



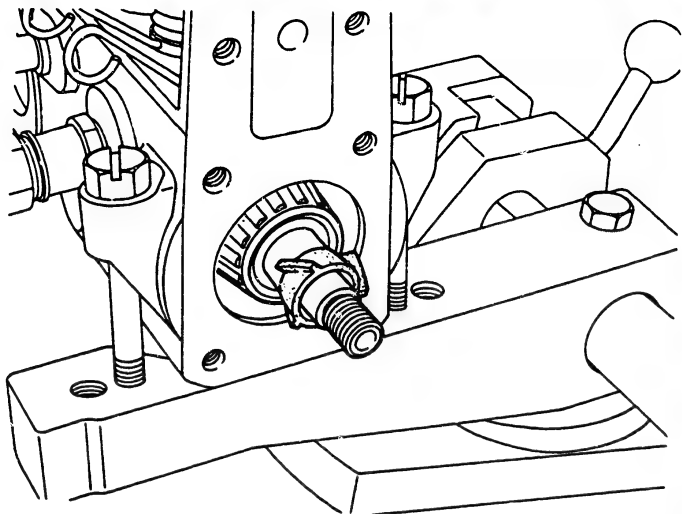

Fig. 32 Removal of impeller

20. Remove the impeller from the camshaft.

C1

Disassembly
RAD-K governor



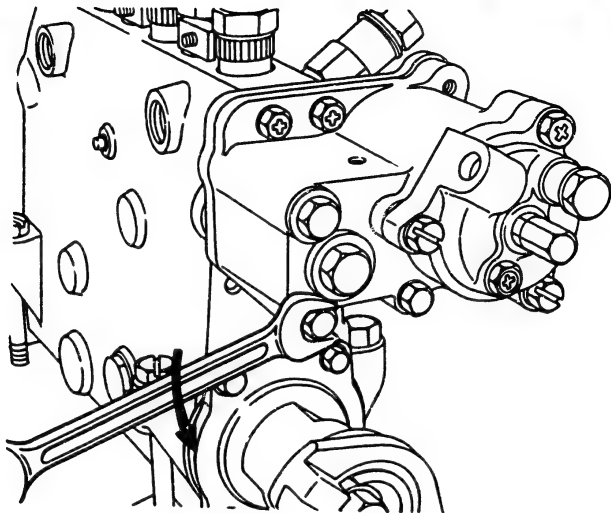

Fig. 33 Removal of bolts

21. Remove the four bolts (65/58 and 65/59 and boost compensator assembly (65).



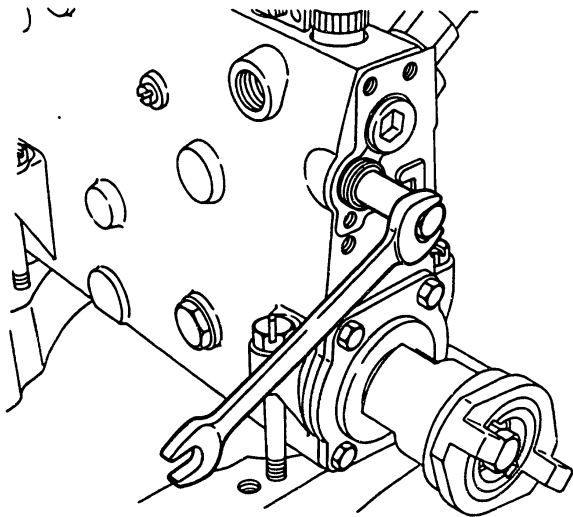

Fig. 34 Removal of bolt

22. Remove the bolt (65/53) then remove the spring washer (65/52), plate (65/51) and spacer (65/50).

C3

Disassembly
RAD-K governor



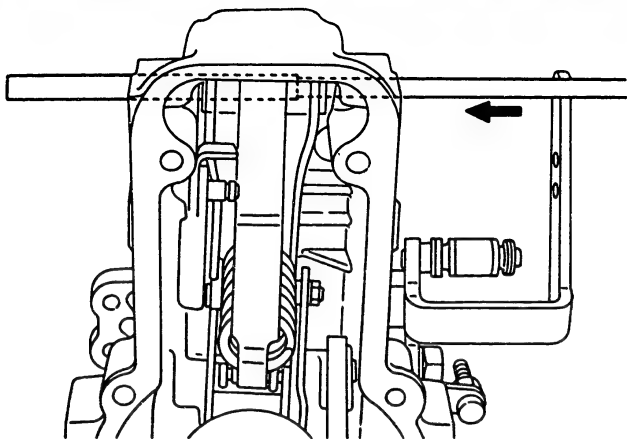

Fig. 35 Drawing out tension lever shaft

23. Removal of governor cover parts

- (1) Draw out the tension lever shaft (182).



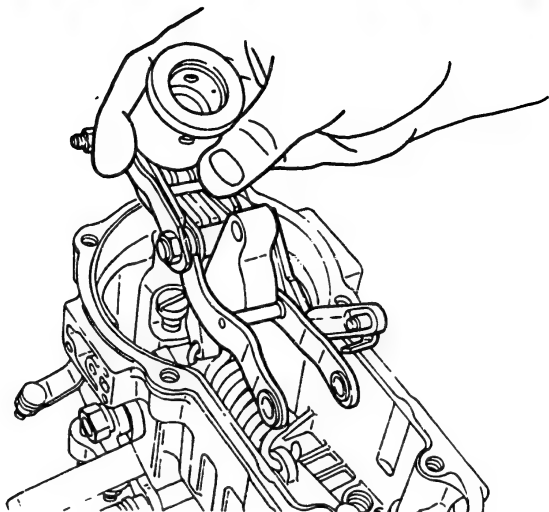

Fig. 36 Removal of guide lever assembly

- (2) After removing both the floating lever block and the tension lever pin (181) from the supporting lever (207), remove the guide lever assembly (170) and the two bushings (183).



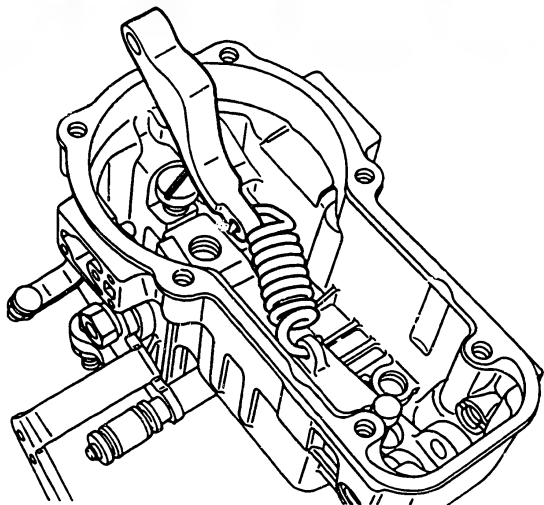

Fig. 37 Removal of speed setting lever

- (3) Detach the speed setting lever (150) from the governor spring (130) and remove.



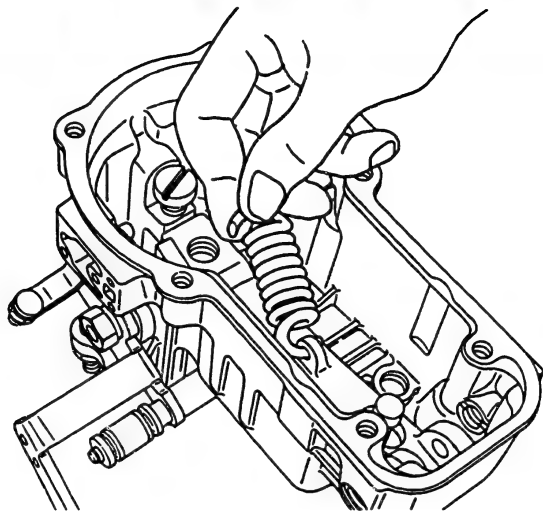

Fig. 38 Removal of governor spring

- (4) Remove the governor spring from the tension lever.

C7

Disassembly
RAD-K governor



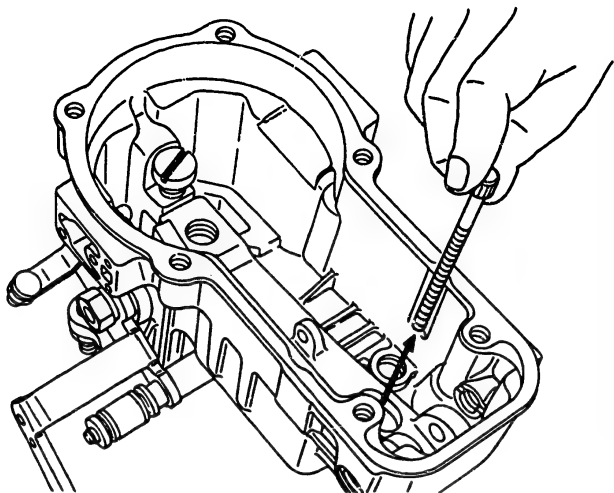

Fig. 39 Removal of speed adjusting screw

- (5) Remove the speed adjusting screw (44) from the inside of the governor cover.**



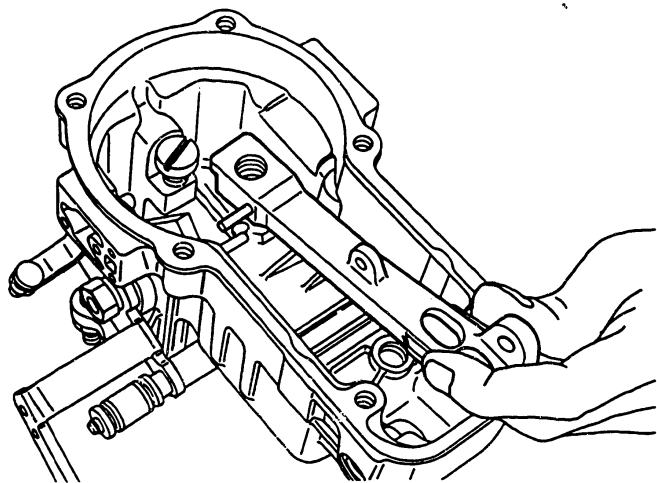

Fig. 40 Removal of tension lever

(6) Remove the tension lever (181).

C9

Disassembly
RAD-K governor



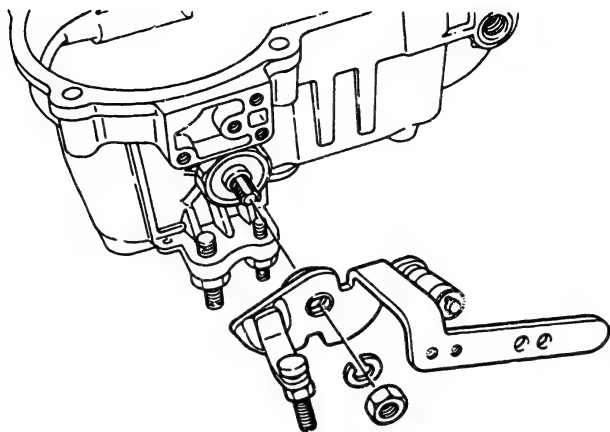

Fig. 41 Removal of load control lever

- (7) Remove the nut (192), and then remove the load control lever (190).

C10

Disassembly
RAD-K governor



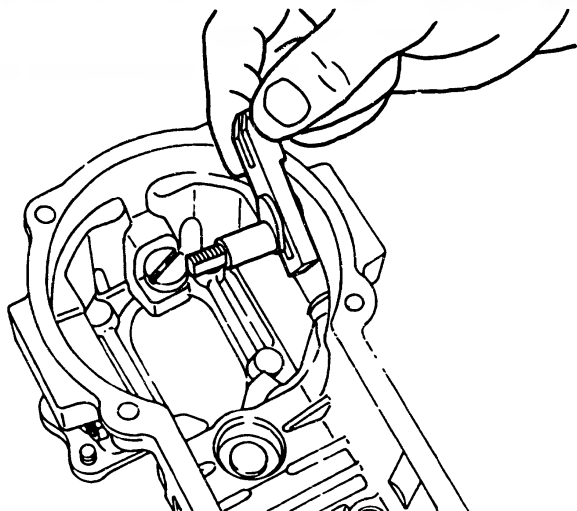

Fig. 42 Removal of supporting lever

- (8) Remove the supporting lever (207) with eccentric shaft (205) attached (from within governor cover).

C11

Disassembly
RAD-K governor



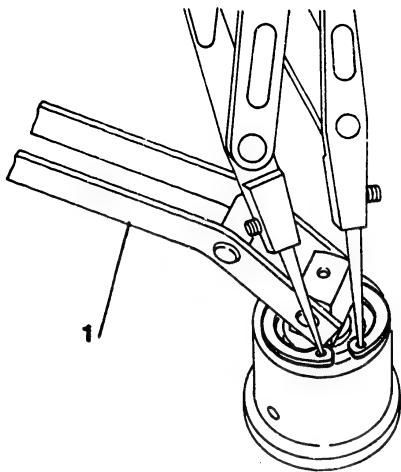
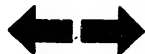

Fig. 43 Removal of snap-ring

1 = Guide lever

(9) Removing the guide lever assembly (170) from the sleeve (117). (This operation is only performed when it is necessary for parts to be replaced.)

-1. Using snap-ring pliers, remove the snap-ring from the sleeve. (Fig. 43)



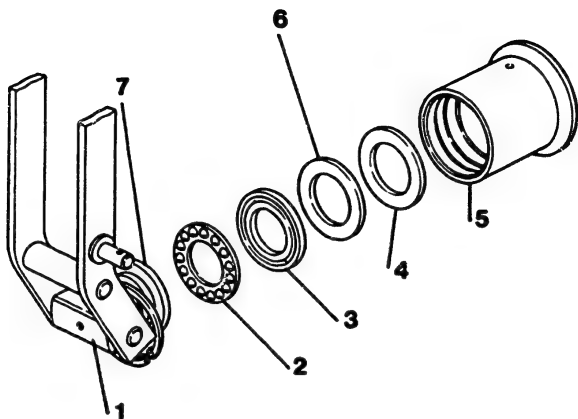

Fig. 44 Sleeve, guide lever assembly and bearing assembly

- 1 = Shifter
- 2 = Ball and cage ass'y
- 3 = Inner ring
- 4 = Washer
- 5 = Sleeve
- 6 = Damper
- 7 = Outer ring

-2. Remove the guide lever assembly and the bearing assembly from the sleeve.



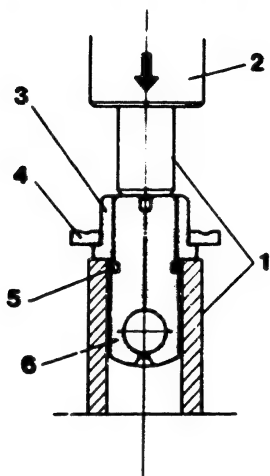

Fig. 45 Removal of bush

- 1 = Guide
- 2 = Press
- 3 = Bush
- 4 = Outer ring
- 5 = Adjusting shim
- 6 = Shifter

-3. Using a press, remove the bush from the shifter.



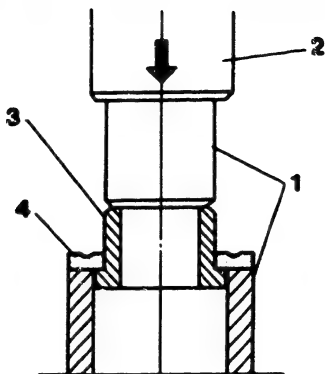

Fig. 46 Removal of outer ring

- 1 = Guide
- 2 = Press
- 3 = Bush
- 4 = Outer ring

-4. Remove the bearing's outer ring from the bush. (Fig. 46)

With the above, disassembly of the RAD (K) type governor is complete.



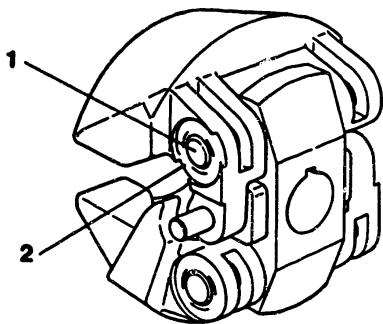

Fig. 47 Flyweight pin section

- 1 = Pin
- 2 = Flyweight

INSPECTION

Wash each disassembled part thoroughly in clean fuel oil and replace any parts which are worn excessively, damaged or rusted, with new parts.

Flyweights

1. When clearance between flyweight pin and flyweight is excessive due to wear, replace flyweight. (Fig. 47)



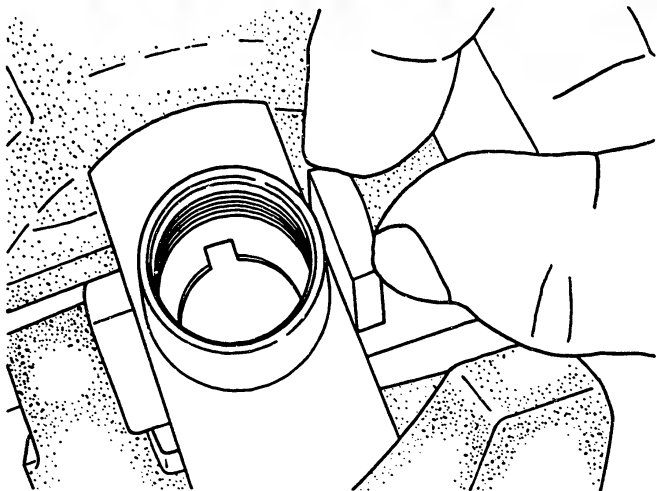

Fig. 48 Check slider for wear

2. When the contact surface between slider and sleeve is worn excessively or clearance between slider and pin is excessive, likewise, replace flyweight.

C17

Inspection
RAD-K governor



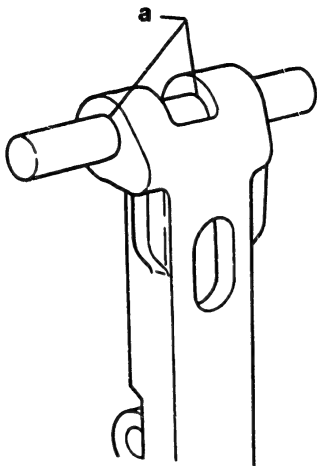

Fig. 49 Inspect clearance between shaft and tension lever

a = Check for wear

Tension lever

- 1.** When clearance between shaft and tension lever is excessive due to wear, replace tension lever.



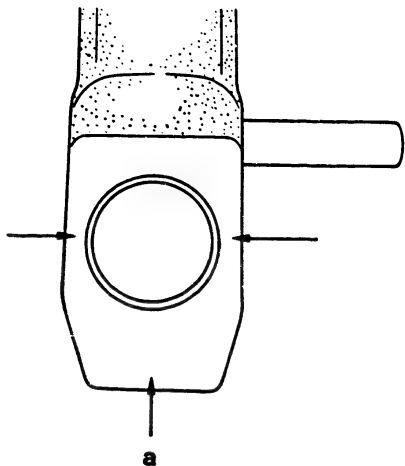

Fig. 50 Inspect each contact section

a = Check for wear

2. When the contact sections between stroke adjusting screw, shifter and supporting lever are worn excessively, replace the tension lever.

C19

Inspection
RAD-K governor



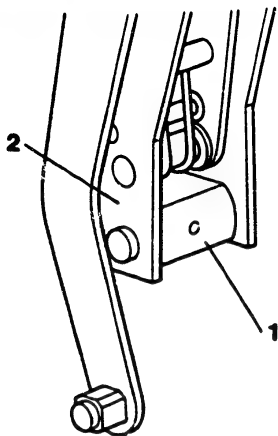

Fig. 51 Inspection of shifter

- 1 = Shifter
- 2 = Guide lever

Guide lever and shifter

1. When the surface of shifter (i.e. its contact surface with tension lever) is worn, (i.e. the chrome plating is peeling off), replace the guide lever assembly.



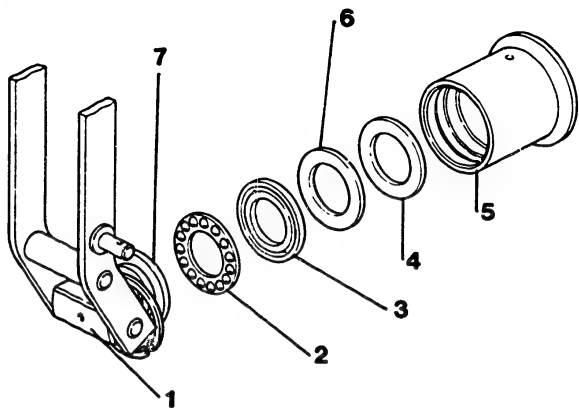

Fig. 52 Inspection of ball bearing

- | | |
|-------------------------|----------------|
| 1 = Shifter | 5 = Sleeve |
| 2 = Ball and cage ass'y | 6 = Damper |
| 3 = Inner ring | 7 = Outer ring |
| 4 = Washer | |

2. A worn ball bearing is primarily responsible for excessive axial play between shifter and sleeve. If worn, replace sleeve assembly. When play in the connection between shifter and guide lever is excessive, replace guide lever assembly.



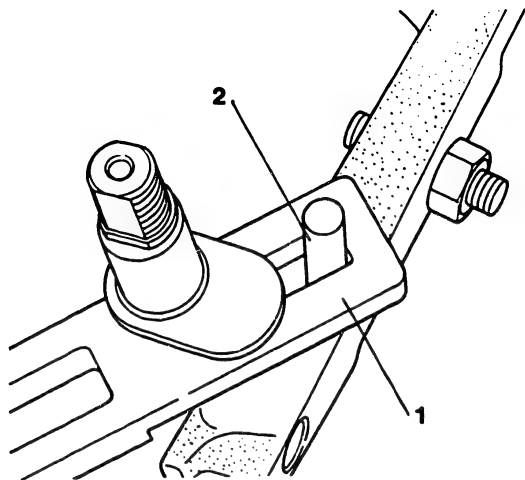

Fig. 53 Inspection of the grooved section for inserting pin

1 = Supporting lever

2 = Tension lever pin

Supporting lever

1. When the groove of the supporting lever is worn excessively, replace supporting lever.



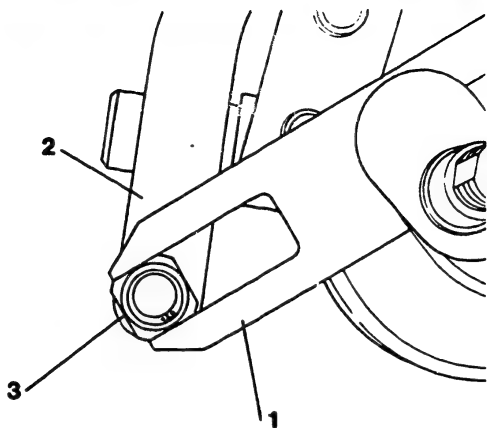

Fig. 54 Inspection of the grooved section of supporting lever

- 1 = Supporting lever
- 2 = Floating lever
- 3 = Block

2. When the surface in contact with the block of floating lever is worn excessively, replace supporting lever.



Load control lever

1. Oil leakage from the shaft portion of the load control lever indicates excessive wear of shaft or bushing.
Replace the worn component with a new one. If only minor wear, replace the oil seal concerned.
2. If abnormal wear is noticed in the section in contact with the respective stopper bolts, replace lever with a new one.

Springs

Replace any springs showing damage (i.e. bent, extended, etc.), flaws or rust.



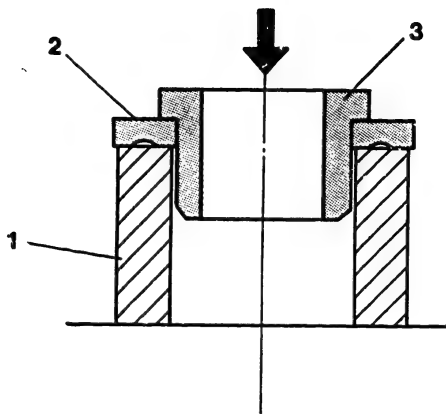

Fig. 55 Press-fitting the bush

- 1 = Guide
- 2 = Outer ring
- 3 = Bush

REASSEMBLY

Reassembly of the RAD or RAD-K type governor, is the reverse of the disassembly procedure. Points requiring special precautions during reassembly are explained below.

Shifter and sleeve reassembly

1. Press-fit the bush to the thrust ball bearing's outer ring.



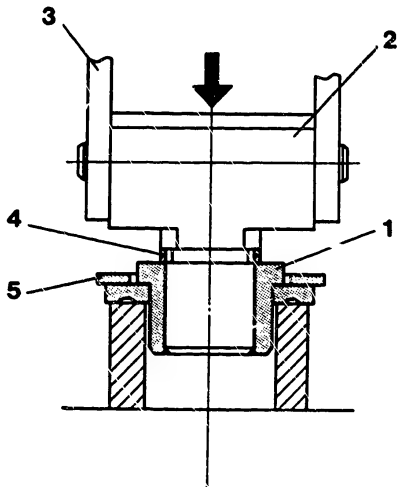

Fig. 56 Press fitting the shifter

- 1 = Bush
- 2 = Shifter
- 3 = Guide lever
- 4 = Shim
- 5 = Snap-ring

2. After placing the snap-ring on the bush, press-fit the shifter to the bush. (Fig. 56)
Do not alter the thickness of the shim inserted between the bush and the shifter.

Note: Take care not to damage the chrome-plated portion of the shifter.



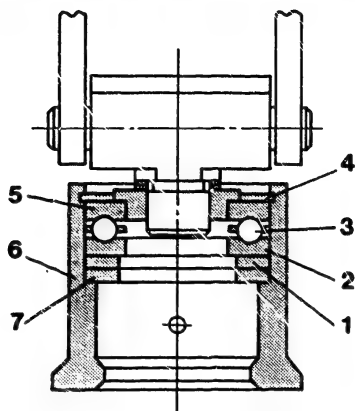

Fig. 57 Reassembling the sleeve

- | | |
|----------------------------|----------------|
| 1 = Damper | 5 = Outer ring |
| 2 = Inner ring | 6 = Sleeve |
| 3 = Ball and cage assembly | 7 = Washer |
| 4 = Snap-ring | |

3. Reassemble the inner ring, ball and cage assembly and shifter in the sleeve, and fix using the snap-ring.

Note: Attach the damper to the sleeve with the metal side of the damper facing the washer.

4. After completion of reassembly fix the shifter and confirm that the sleeve rotates smoothly.



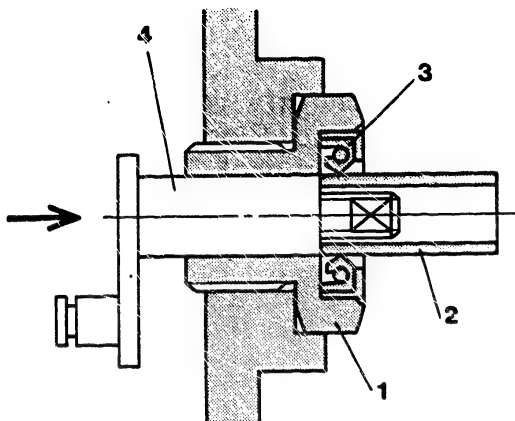

Fig. 58 Mounting the eccentric shaft

- 1 = Bush
- 2 = Guide
- 3 = Oil seal
- 4 = Eccentric shaft

Reassembly of governor cover inner components

1. Use a guide when mounting the eccentric shaft (205) in the bushing of the governor cover so that the oil seal will not be damaged.



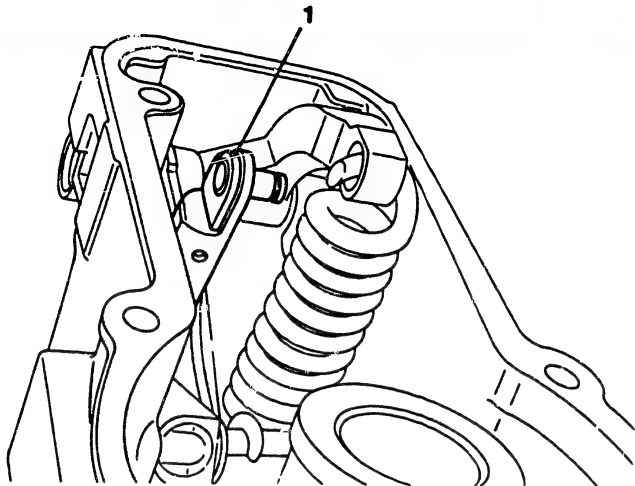

Fig. 59 Assembly position for governor spring

1 = Link

2. After installing supporting lever and load control lever on governor cover, incorporate (together with guide lever assembly) the speed setting lever and tension lever (both of which remain connected with governor spring) into governor cover.

Ensure governor spring has its hooked portion, which is shaved flat, facing link (174) when connecting speed setting lever. (Fig. 59)

D1

Reassembly
RAD-K governor

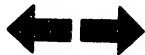

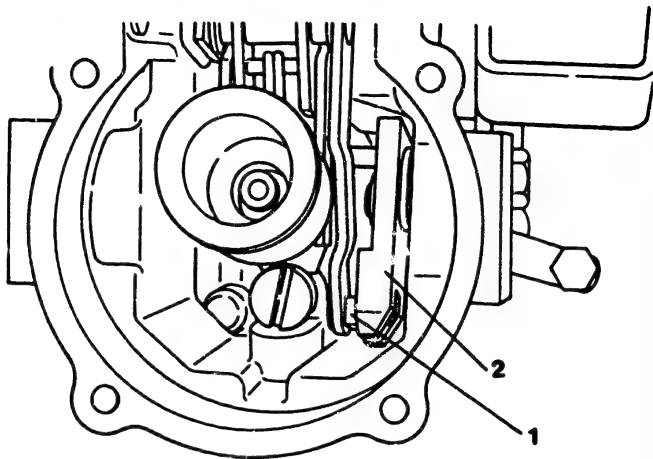

Fig. 60 Check to see that pin and block are properly assembled

- 1 = Block
- 2 = Supporting lever

3. Make sure the groove in supporting lever securely holds tension lever pin and the block of floating lever.

D2

Reassembly
RAD-K governor



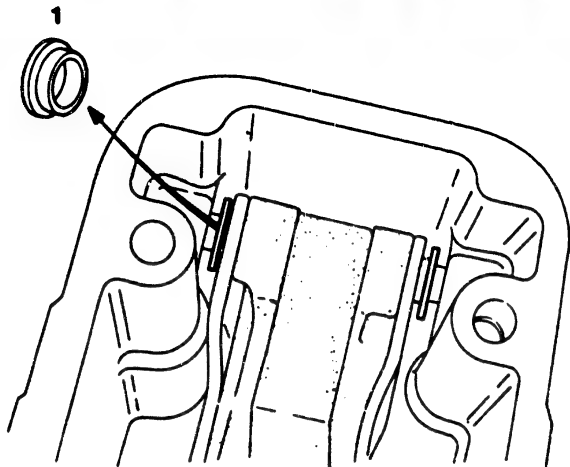

Fig. 61 Assembling shaft

1 = Bush

4. Next, incorporate the pin. Ensure that bushings (183) are inserted.

Note: During this operation, pin and block sometimes come off sliding lever. Recheck as per point 2 above.

D3

Reassembly
RAD-K governor



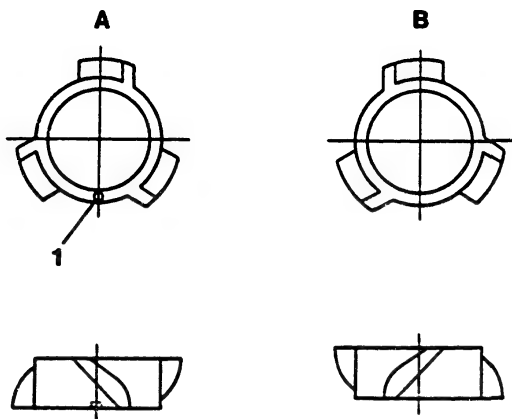

Fig. 62 Impeller

- A = For clockwise rotation
(with distinguishing groove)**
B = For counterclockwise rotation
1 = Groove

Impeller

After mounting the governor housing, attach the impeller to the camshaft with the flat side of the blades facing the governor.

Depending on the direction of pump rotation, two types of impeller are available. (Fig. 62)

*) Counterclockwise rotation : 155412-5200

*) Clockwise rotation : 155412-5300

*) Bosch Nr., see cross reference DKKC - Bosch, microfiche HB 30, HB 31.

D4

Reassembly
 RAD-K governor



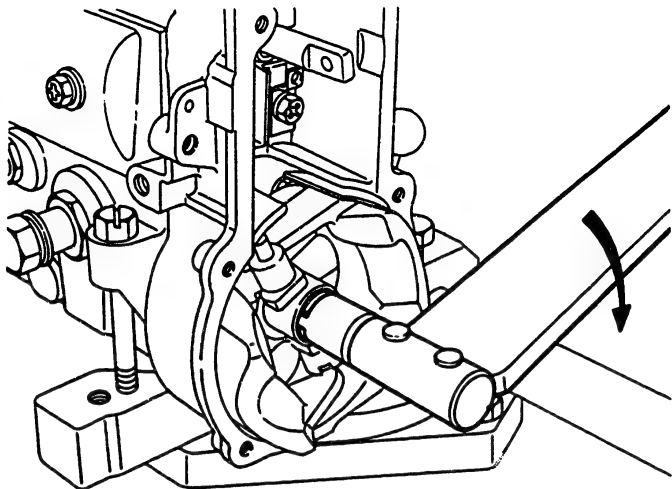

Fig. 63 Tightening of roundnut

Mounting of flyweight

Tighten roundnut (103) of flyweight securely to the specified torque. (Fig. 63)

Specified tightening torque: 5 to 6 kg-m.

Assembling instructions

Assemble and temporarily set full-load stopper bolt, stroke adjusting bolt, idling spring, torque control springs, maximum-speed setting screw, etc. Adjust them on a pump test stand to the respective standard values.



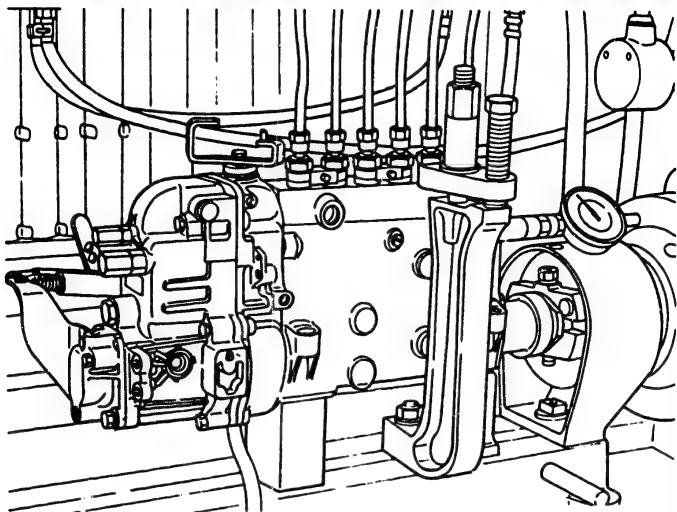

Fig. 64 Mounting injection pump

ADJUSTMENT

Preparations

1. Mount the injection pump assembly securely on a pump test stand. Then, attach the test nozzle and nozzle holder assembly, test lines and measuring device to measure control rack travel, to the injection pump. (Fig. 64)
2. Remove the damper spring (220), cover (80), torque control spring (331) and idling spring (140), and loosen adjusting screw (181/3).

D6

Adjustment
RAD-K governor



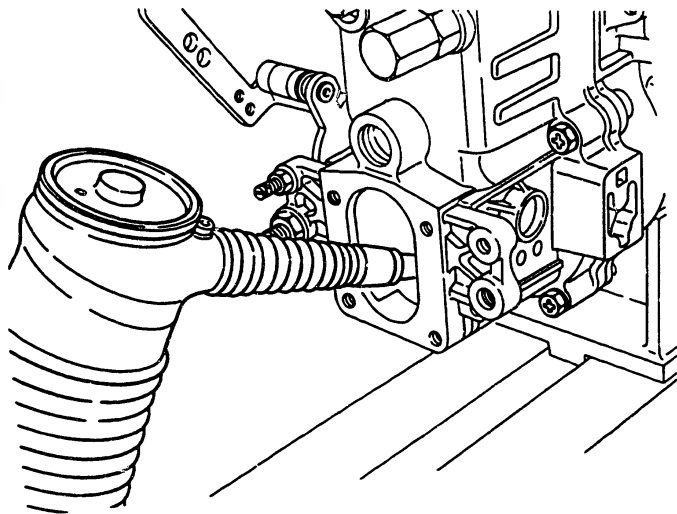

Fig. 65 Supplying oil

3. Fill governor chamber and camshaft chamber with injection pump oil.

Cam chamber: 15cc for every cylinder

Governor chamber: 200 cc

D7

Adjustment

RAD-K governor



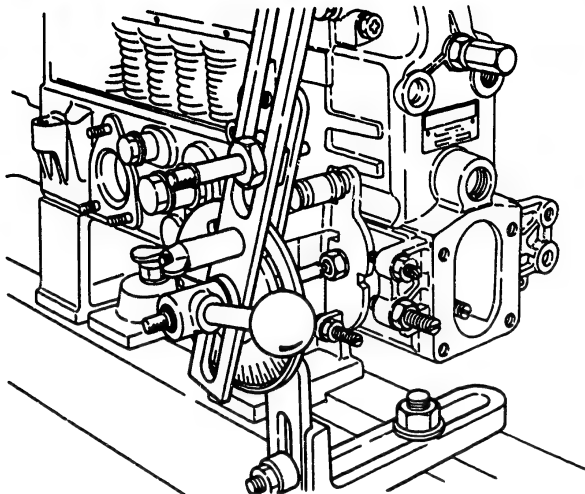

Fig. 66 Mounting measuring device

4. Mount a measuring device (0 681 440 006) to measure the load control lever angle.

D8

Adjustment
RAD-K governor



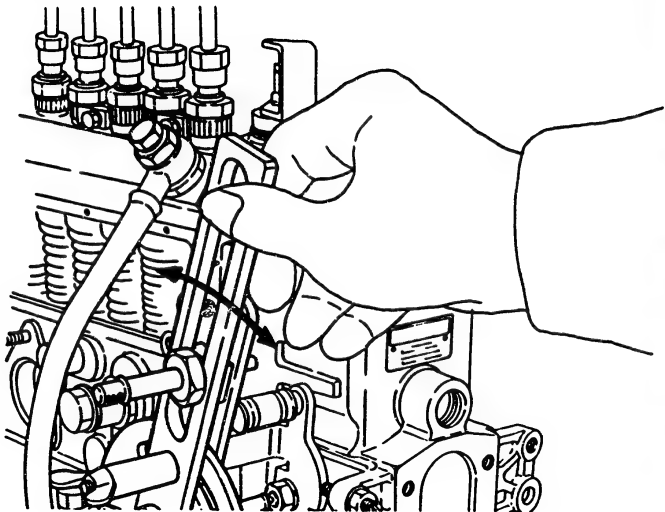

Fig. 67 Checking control rack movement

5. With injection pump "off", ensure, by moving load control lever in both "fuel-increase" and "fuel-decrease" directions, that control rack travels smoothly.

09

Adjustment
RAD-K governor



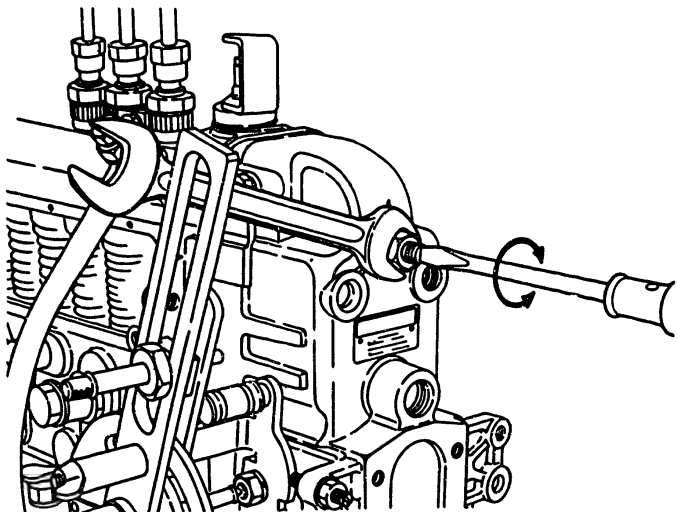

Fig. 68 Temporary fixing of speed setting screw

Setting the control rack zero point

1. After fixing load control lever in the "idling" position, temporarily set speed adjusting screw so that governor begins to move the control rack in the "fuel-decrease" direction at pump speed of 500 to 600 rpm.

D10

Adjustment

RAD-K governor

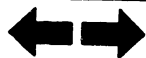

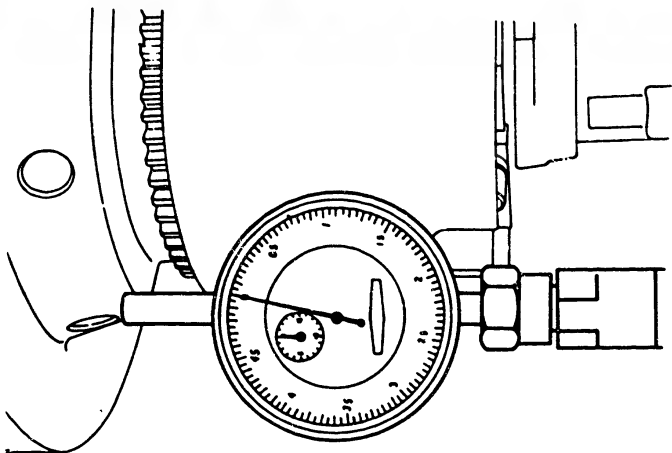

Fig. 69 Setting "zero" point

2. Increase the pump speed so that the control rack travels to the non-injection position.

Then, press the control pinion with a screw driver until control rack stops. Make this position the "zero" point of the control rack, and set the measuring device pointer to correspond with "zero" of the scale. (Fig. 69)

Note: The operation of the stopping lever will not cause the control rack to travel to "zero" point.



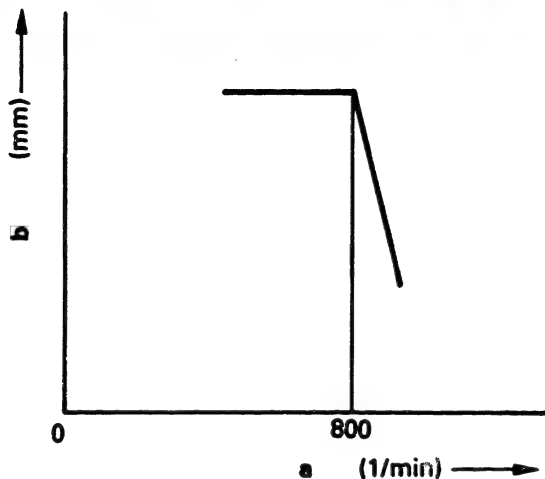

Fig. 70 Torque control stroke
(RAD-K type only)

a = Pump speed (rpm)
b = Control rack position

1. Fix the load control lever in the "full-load" position.
2. Temporarily hold the speed control lever in position so that governor begins to move the control rack in the "fuel-decrease" direction at pump speed of approx. 800 rpm. (Fig. 70)



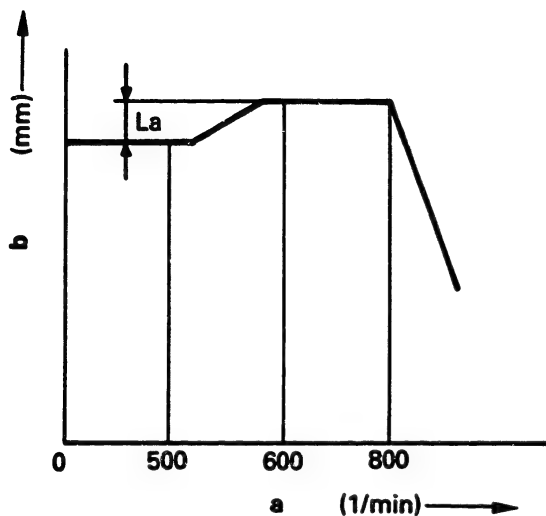

Fig. 71

a = Pump speed (rpm)
 b = Control rack position

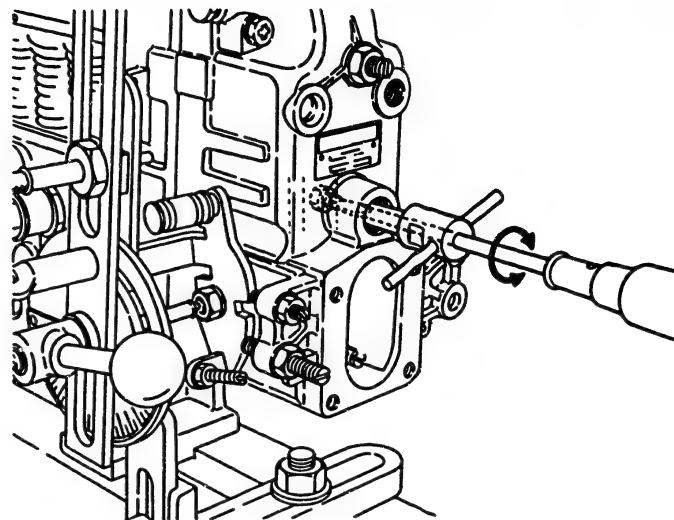

Fig. 72 Adjustment of torque control stroke

3. Using a wrench make adjustments by means of adjustment screw (181/3), while raising and lowering pump speed within the range of 500 to 600 rpm; specified value "La". (Figs. 71 and 72).

D13

Adjustment
 RAD-K governor



D14

Adjustment
 RAD-K governor



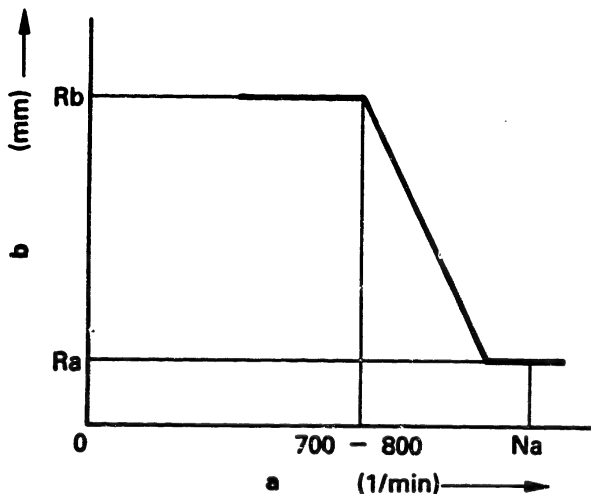

Fig. 73 Flyweight lift and full load position
(common to RAD and RAD-K)

a = Pump speed (rpm)
b = Control rack position

The total lift of the flyweight is divided into two categories; one for high-speed control and the other for idling control. Firstly, adjust the flyweight lift for high-speed control.

1. Fix the load control lever at "full" position (control rack position "Rb"), and temporarily set speed setting screw so that governor begins to move the control rack in the "fuel-decrease" direction at pump speed of 700 to 800 rpm.



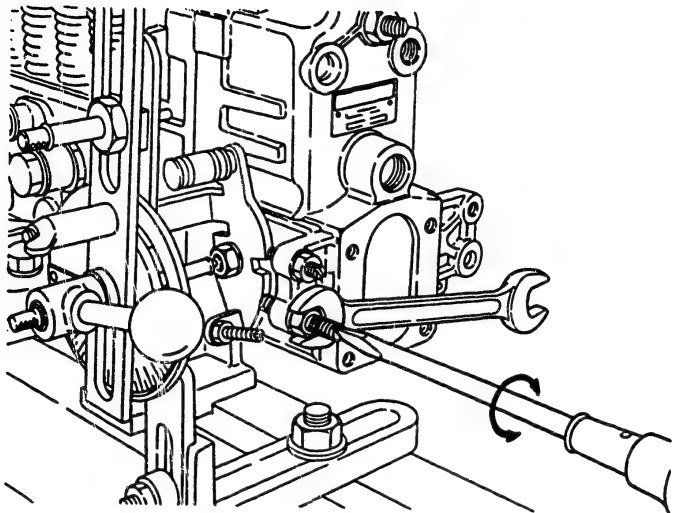

Fig. 74 Adjustment of control rack position "Ra"

2. While raising pump speed to "Na", make adjustments by means of full-load stopper bolt (48) so that control rack position corresponds with "Ra". (Figs. 73 and 74)

Notes: 1. The control rack position "Ra" equals control rack position "Rb" minus the travel "L". (Fig. 75)
2. If "Ra" is below "zero", set the control rack to the "Ra plus 2 mm" position.



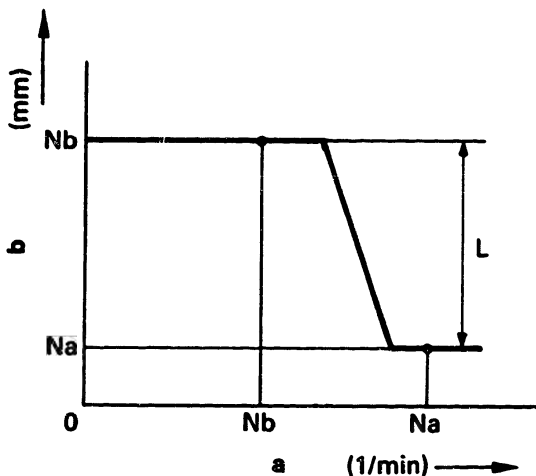

Fig. 75 RAD governor

a = Pump speed (rpm)
 b = Control rack position

- Next, decrease pump speed to "Nb" and, by means of stroke adjusting screw (38) adjust flyweight lift for high-speed control "L" (control rack position "Rb"). (Figs. 75, 76 and 77)

Note: If the control rack is set to the "Ra plus 2 mm" position in Step 2, set the stroke adjusting screw to the "Rb plus 2 mm" position.



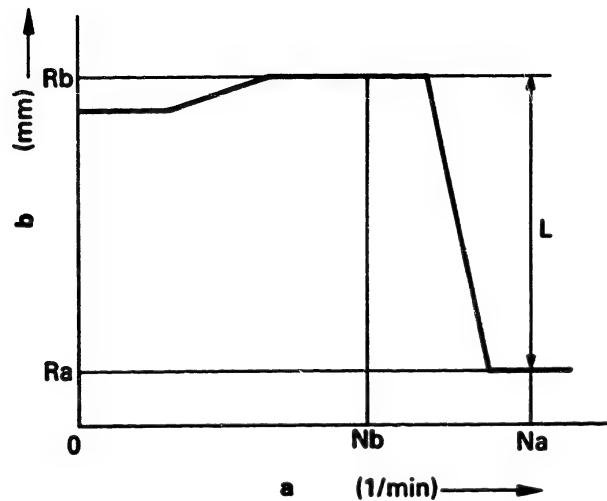

Fig. 76 RAD-K governor

a = Pump speed (rpm)
 b = Control rack position

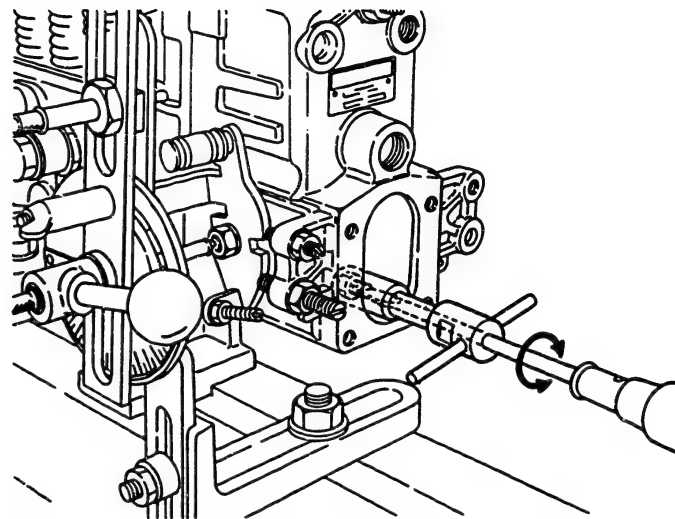

Fig. 77 Adjustment of flyweight lift for high-speed control "L"

D18

Adjustment
 RAD-K governor



D19

Adjustment
 RAD-K governor

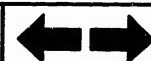

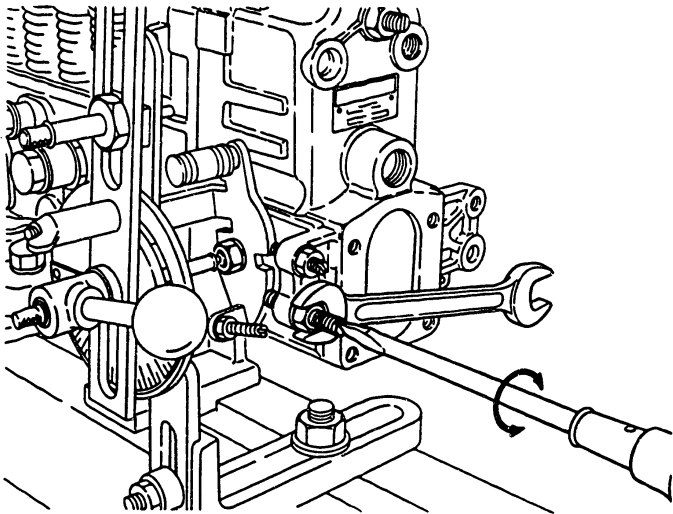

Fig. 78 Readjust full-load stopper bolt

4. Readjust the full-load stopper bolt to the "full-load fuel injection quantity" position according to the service data.

D20

Adjustment
RAD-K governor



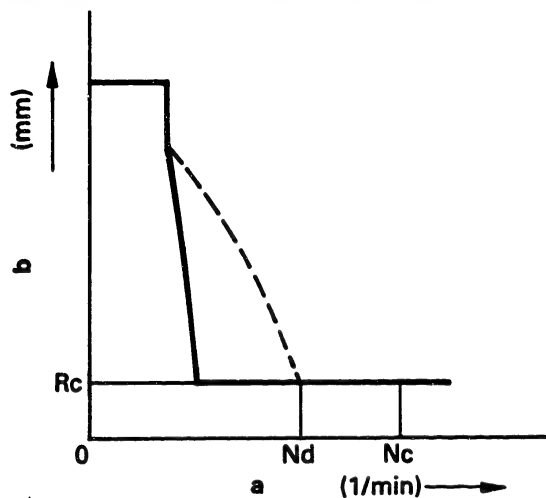

Fig. 79

a = Pump speed (rpm)
 b = Control rack position

Idling
 (common to RAD and RAD-K)

1. Run injection pump at "Nc" (Nd plus 100 rpm).
2. Make adjustments by means of idling adjustment screw (50), so that control rack position corresponds with "Rc".
 (Figs. 79 and 80)

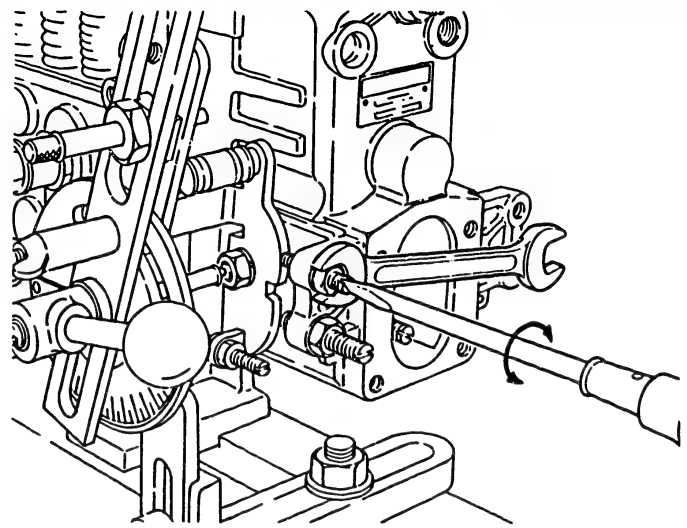

Fig. 80 Adjustment of control rack position "Rc"

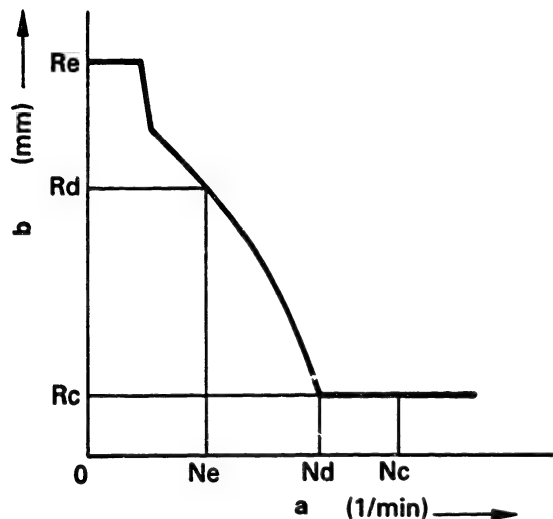

Fig. 81

a = Pump speed (rpm)
b = Control rack position

3. Decrease pump speed so as to maintain "Ne" rpm.
4. Incorporate idling spring assembly (140) into tension lever. Screw in the assembly until control rack position corresponds with "Rd", and then lock it at this point, with a wrench (KDEP 2604). (Figs. 81 and 82)

Note: At this time, pump speed may sometimes drop.
Ascertain that "Ne" rpm is maintained.

5. Make sure control rack position remains above "Re" even when pump speed is decreased to 0 rpm. (Fig. 81)
6. Next, increase pump speed slowly and ensure that when control rack reaches position "Rc" the corresponding speed is "Nd" rpm. (Fig. 81)

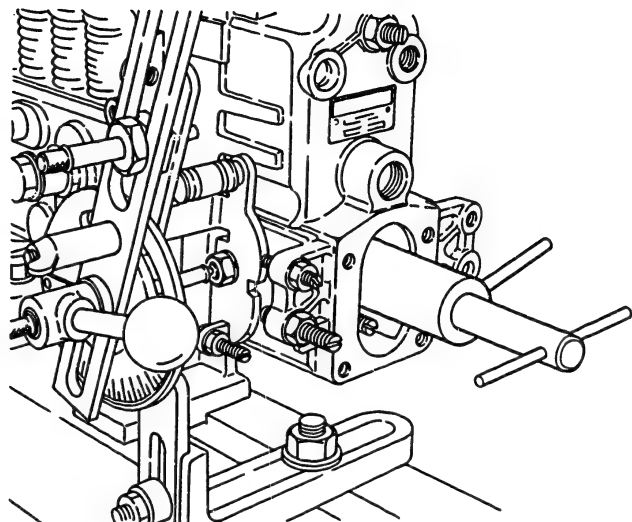

Fig. 82 Adjustment of idling spring

D23

Adjustment
RAD-K governor



D24

Adjustment
RAD-K governor



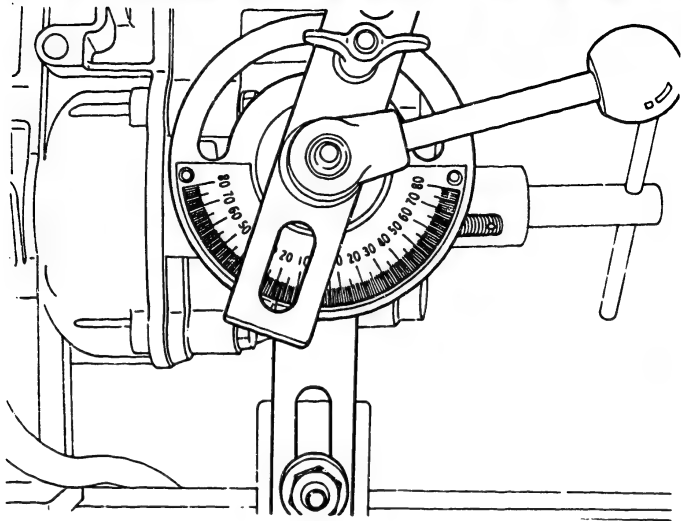

Fig. 83 Confirmation of load control lever angle

7. Measure the load control lever angle at the idling position. (Fig. 83)
 - When load control lever is depressed toward the "full" position side, replace shifter shim with a thicker one.
 - When load control lever is depressed toward the "idling" position side, replace shifter shim with a thinner one.



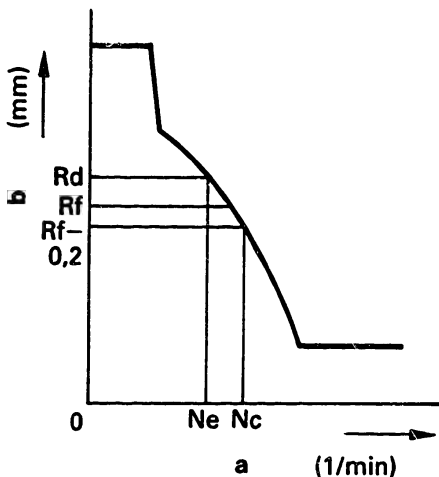

Fig. 84 Damper spring
(common to RAD and RAD-K)

a = Pump speed (rpm)
 b = Control rack position

1. Fix the load control lever at "idling" control position.
2. Increase pump speed slowly from "idling" speed (N_e rpm) to the speed where control rack position corresponds with R_f minus 0.2 mm, and maintain this speed. (Fig. 84)



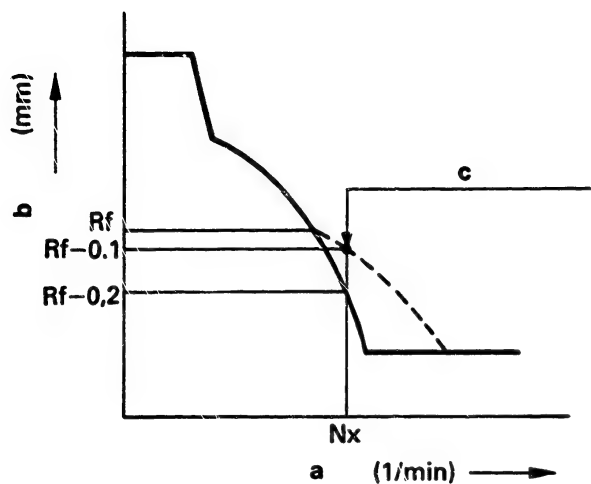

Fig. 85 Set position of damper spring

- a = Pump speed (rpm)
- b = Control rack position
- c = Set position of damper spring

3. Screw in damper spring until control rack position corresponds with R_f minus 0.1 mm, and lock the spring at this point. (Figs. 85 and 86)

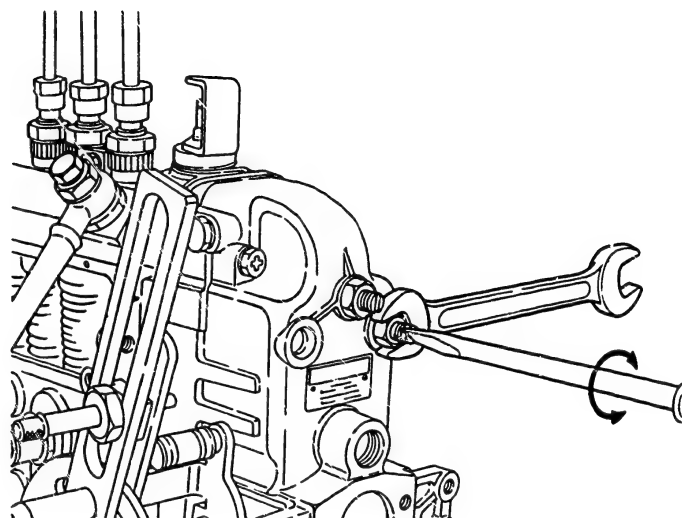

Fig. 86 Setting of damper spring

D27

Adjustment
RAD-K governor



D28

Adjustment
RAD-K governor

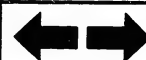

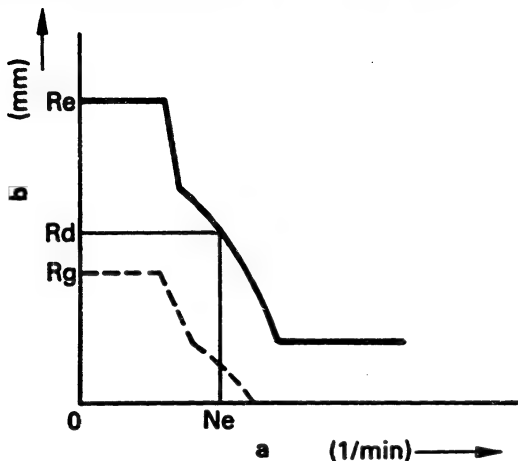

Fig. 87 Stopper bolt
(common to RAD and RAD-K)

a = Pump speed (rpm)
b = Control rack position

If idling performance is included in service data, as represented by dotted line in Fig. 87, adjust stopper bolt (50) setting.

1. After setting damper spring, when pump speed is decreased to 0 rpm, control rack position moves to "Re". (Fig. 87)
2. After loosening stopper bolt, move the load control lever until control rack position is "Rg" and set stopper bolt at this point. (Figs. 87 and 88)

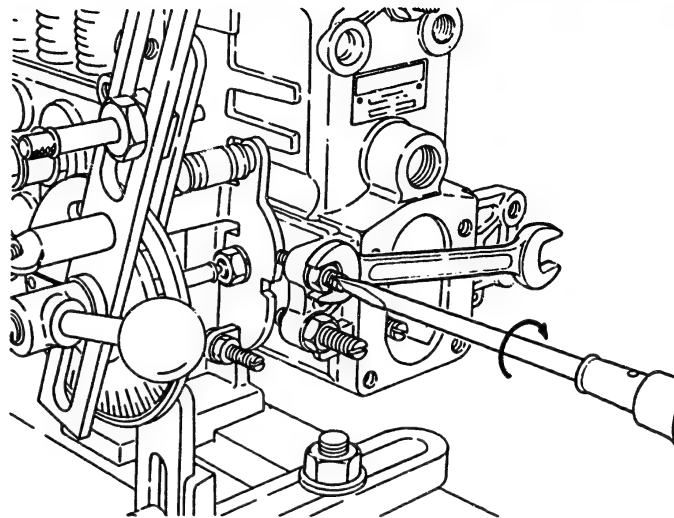

Fig. 88 Setting of stopper bolt

E1

Adjustment
RAD-K governor



E2

Adjustment
RAD-K governor



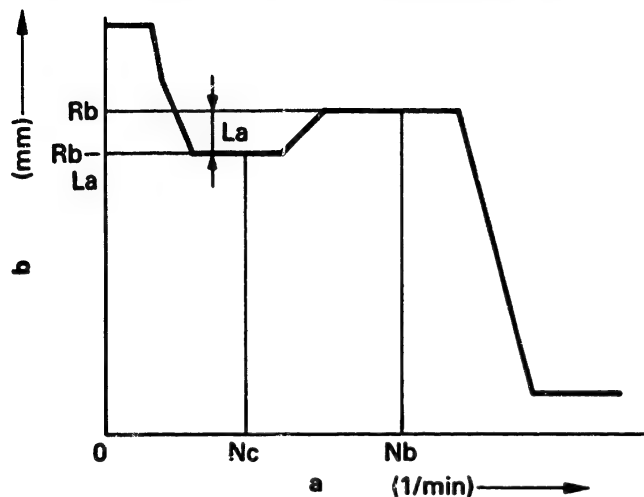

Fig. 89 Torque control range
(RAD-K only)

a = Pump speed (rpm)
b = Control rack position

1. Fix the load control lever at full load position.
2. Ensure that, when pump speed is "Nc" rpm, the corresponding control rack position is "Rb" - "La". Furthermore, ensure that when pump speed is "Nb" the corresponding control rack position is "Rb". (Fig. 89)
3. When pump speed is "Nc" rpm fit the torque control spring assembly (331) into guide screw (141), and lock it with lock nut (141) immediately before control rack position "Rb" - "La" changes. (Figs. 89 and 90)

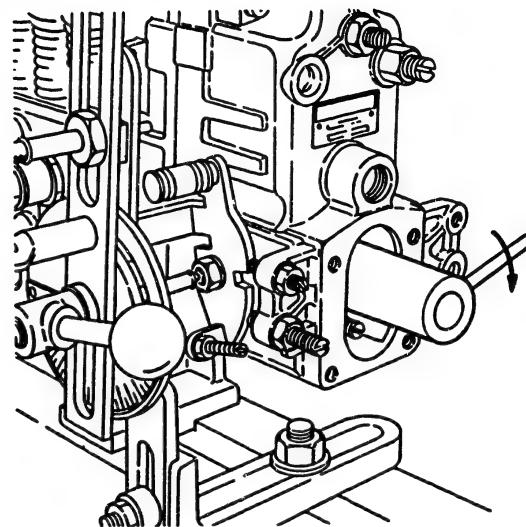

Fig. 90 Adjustment of torque control spring

E3

Adjustment
RAD-K governor



E4

Adjustment
RAD-K governor



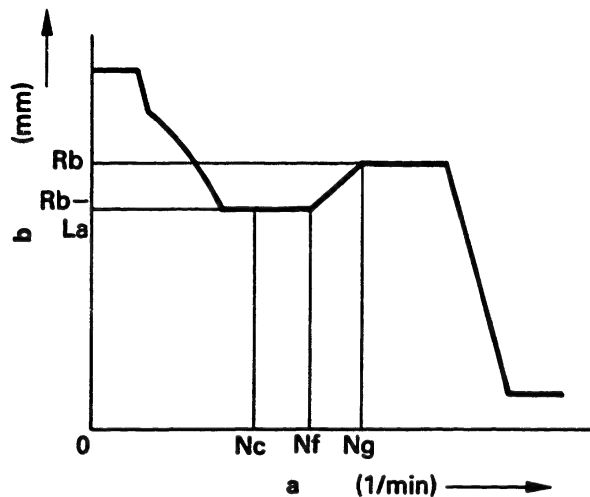

Fig. 91 Torque control range
(RAD-K only)

a = Pump speed (rpm)
b = Control rack position

4. Raise pump speed to "Nf" and ensure that control rack commences to travel in the "fuel-increase" direction. If not to specification adjust the control rack position with the torque control spring assembly cap and nut. (Figs. 91 and 92)
5. Confirm that "Ng" rpm represents the pump speed when the torque control spring stops moving at control rack position "Rb" mm. (Fig. 91)

Note: If high-speed control commences during the operation of the torque control spring, regulate high-speed control.

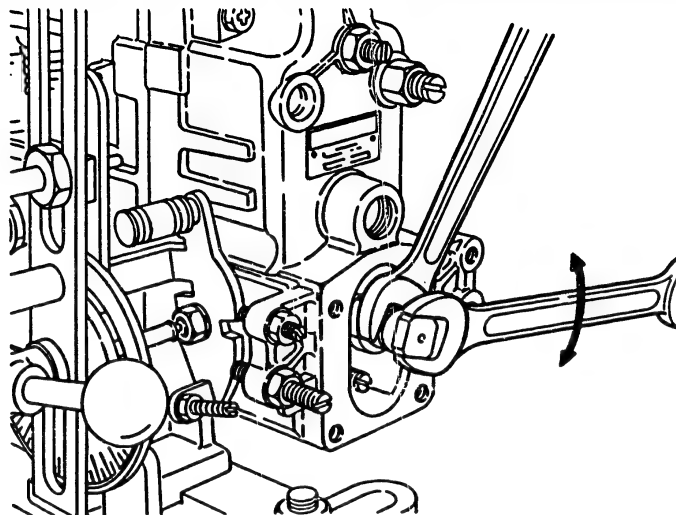

Fig. 92 Adjusting the torque control spring
setting force

E5

Adjustment
RAD-K governor



E6

Adjustment
RAD-K governor



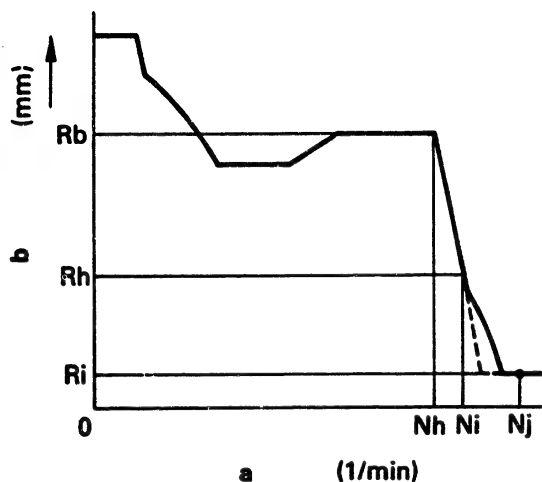

Fig. 93 High-speed control starting point and speed droop check (common to RAD and RAD-K)

a = Pump speed (rpm)
b = Control rack position

1. Fix the load control lever at "full" position.
2. Raise pump speed slowly to "Nh" rpm. Make adjustments to setting screw (44) so that control rack commences to travel from position "Rb". (Figs. 93 and 94)
3. Ensure by raising pump speed that it remains below "Ni" rpm when control rack position reaches "Rh". (Fig. 93)

Note:

When "Ni" rpm exceeds the standard value, the no-load maximum speed of the engine is also increased, which is dangerous. Recheck both "Rb", (full-load rack position) and "Rf" -0.1 mm, (the set position of damper spring).

4. Further increase the pump speed to "Nj" rpm and ensure the control rack is positioned at "Ri" mm. (Fig. 93)

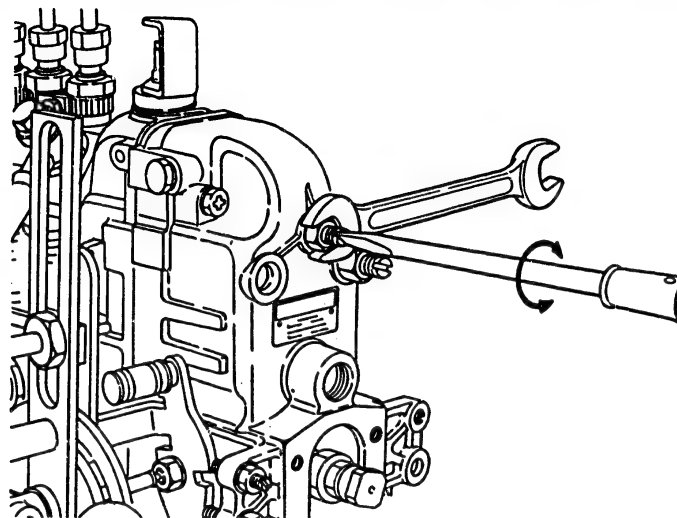

Fig. 94 Adjustment of high-speed control starting point

E7

Adjustment
RAD-K governor



E8

Adjustment
RAD-K governor

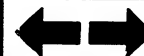

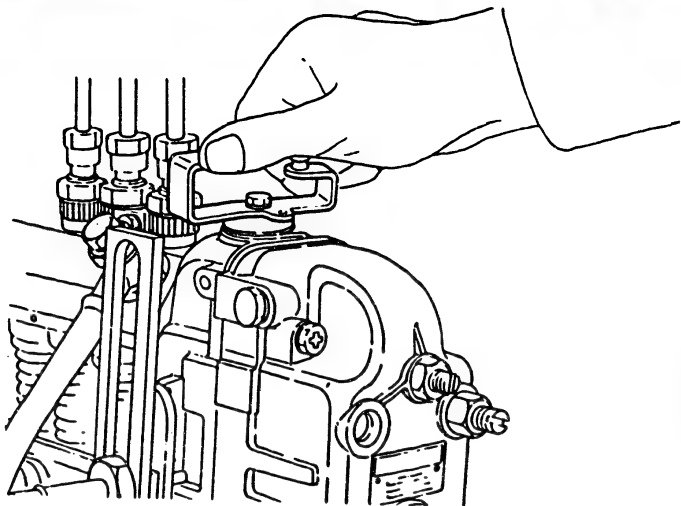

**Fig. 95 Confirmation of the non-injection zone
Stopping lever**

1. Fix the load control lever at "full" position.
2. Maintain the pump speed at approx. 800 rpm.
3. Move the stopping lever to the "fuel-decrease" position and ensure the control rack reaches the non-injection zone (injection quantity of less than 3 cc per 1000 strokes). (Fig. 95)
4. Check that the control rack moves smoothly to the "full-load" position when releasing the stopping lever.

E9

Adjustment
RAD-K governor



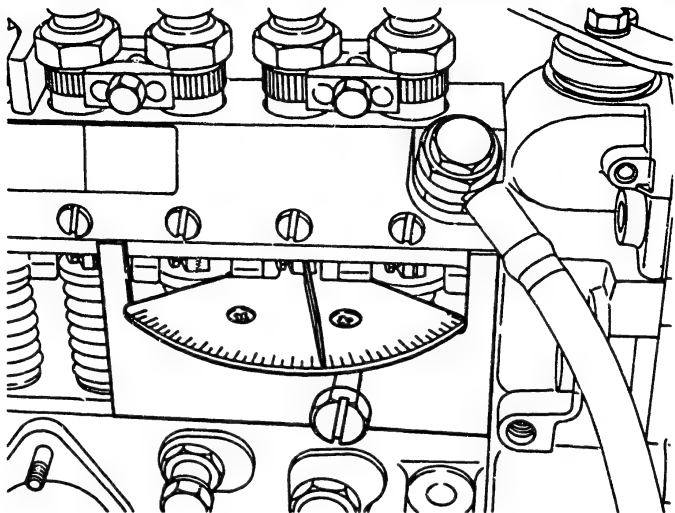

Fig. 96 Attaching the measuring device

**Smoke limiter
(common to RAD and RAD-K)**

- 1. Attach the measuring device (0 681 440 009)
to the plunger spring chamber.**

E10

**Adjustment
RAD-K governor**



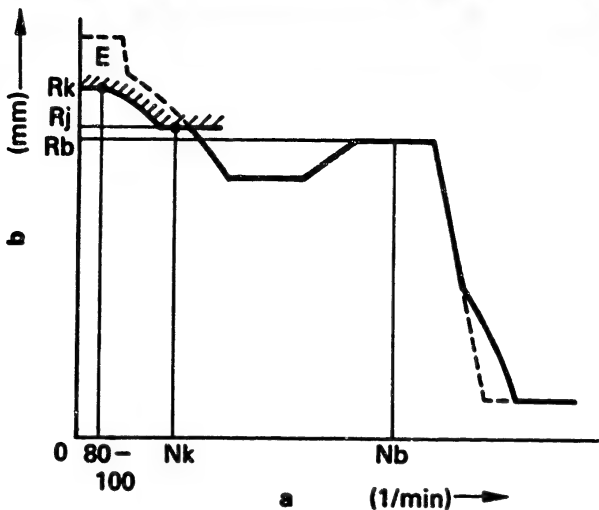

Fig. 97 Smoke limiter performance

a = Pump speed (rpm)
 b = Control rack position

2. Fix the load control lever at "full" position.
3. Maintain the pump speed at "Nb" rpm. (Fig. 97)
4. Fix the measuring device scale plate with the indicator at control rack position "Rb" mm.

E11

Adjustment
 RAD-K governor



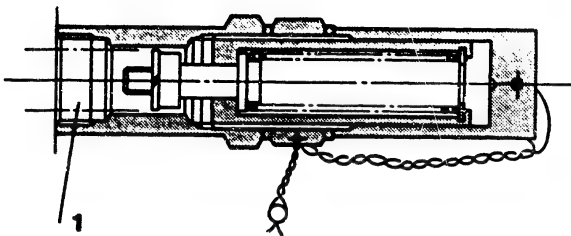

Fig. 98 Smoke limiter

1 = Control rack

5. Remove the measuring device (1 688 130 130) attached to the control rack tip and attach the smoke limiter.

E12

Adjustment

RAD-K governor



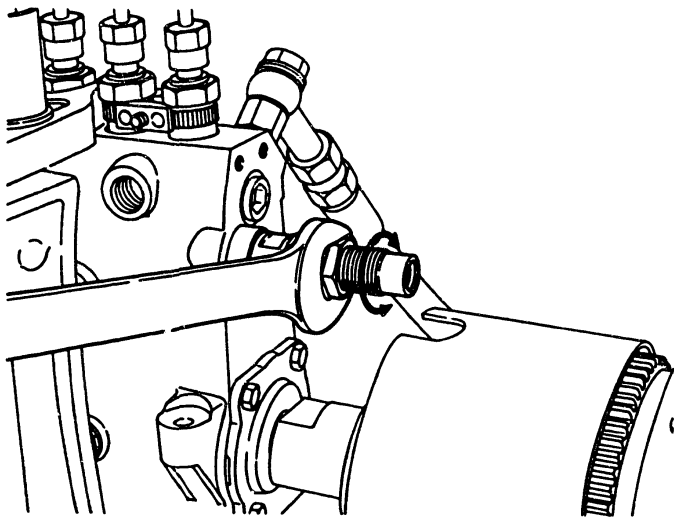

Fig. 99 Adjustment of smoke limiter

6. Maintaining the pump speed at "Nk" rpm, adjust and set the control rack in "Rj" mm position (normally "Rb" plus 0.2 mm) with the smoke limiter spring capsule. (Fig. 99)
7. Reduce the pump speed to 80 - 100 rpm, then check that the control rack position is "Rk". Check the fuel injection quantity for "engine start" at point E. (Fig. 97)



Boost compensator

The method of adjustment of the improved type boost compensator (adjustable spring setting force type) is explained below.

Fig. 100 shows a cross section of the boost compensator.

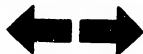

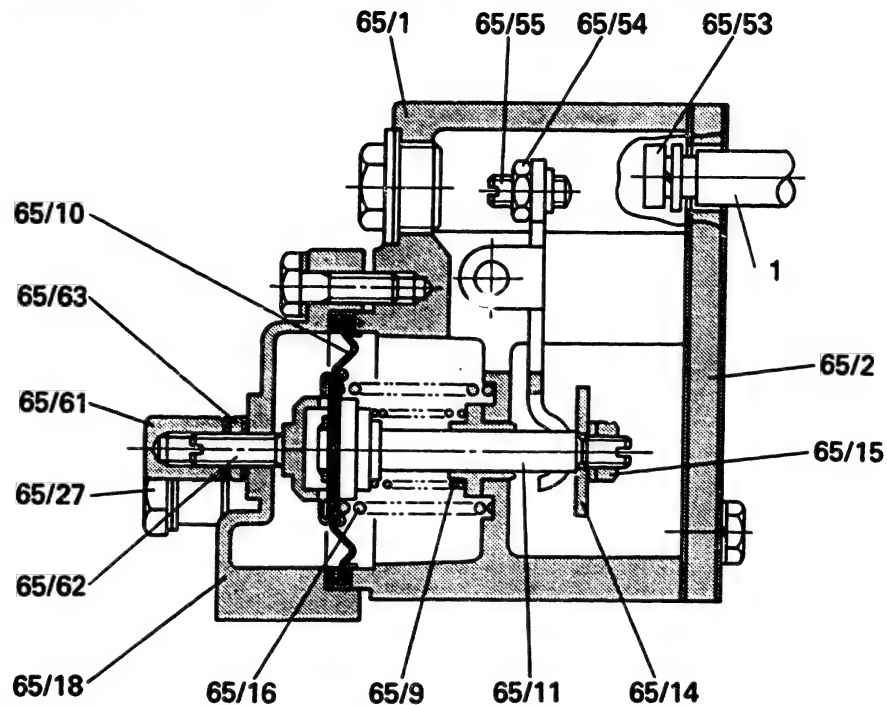

Fig. 100 Boost compensator installed on the drive side

Key No	Part Name	Key No	Part Name	Key No	Part Name
65/1	Housing	65/15	Nut	65/55	Screw
65/2	Spacer	65/16	Spring	65/61	Cap nut
65/9	Spring	65/18	Cover	65/62	Screw
65/10	Diaphragm	65/27	Eye bolt	65/63	Nut
65/11	Pushrod	65/53	Bolt		
65/14	Disk	65/54	Nut		

1 = Control rack

E15

Adjustment
RAD-K governor



E16

Adjustment
RAD-K governor



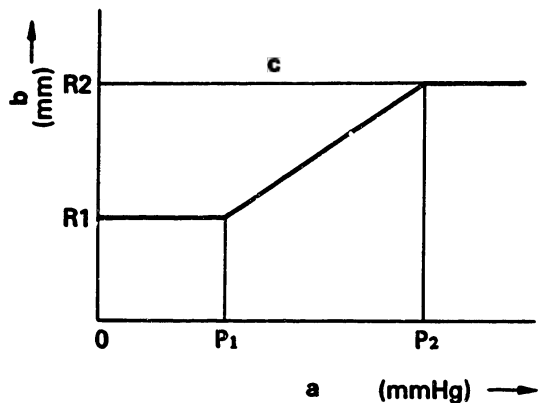

Fig. 101 Boost compensator performance

a = Boost pressure
 b = Control rack position
 c = Pump speed measured in terms of "Np" rpm

The "full-load" rack position "R1" is equivalent to "Rb" - "La" mm (previously given).

For adjustment of the boost compensator, an air compressor equipped with regulator and pressure gauge is required.

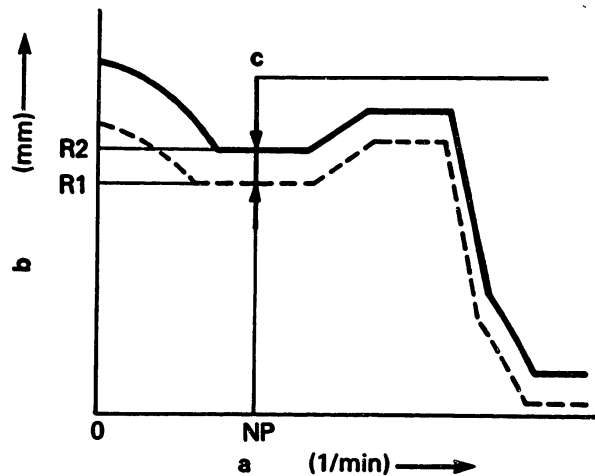
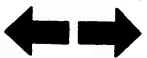

Fig. 102 Governor "full-load" performance

a = Pump speed (rpm)
 b = Control rack position
 c = Boost compensator stroke

E17

Adjustment
 RAD-K governor



E18

Adjustment
 RAD-K governor

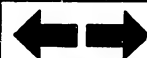

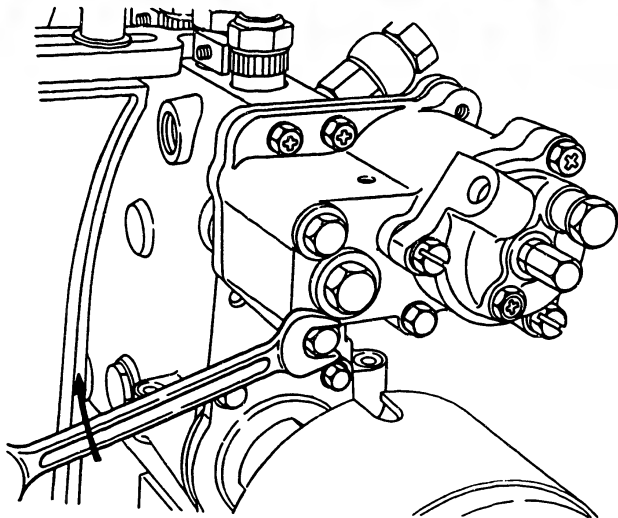

Fig. 103 Attaching the boost compensator

1. After completion of general adjustment of the RAD(K) type mechanical governor, attach the boost compensator to the pump housing.



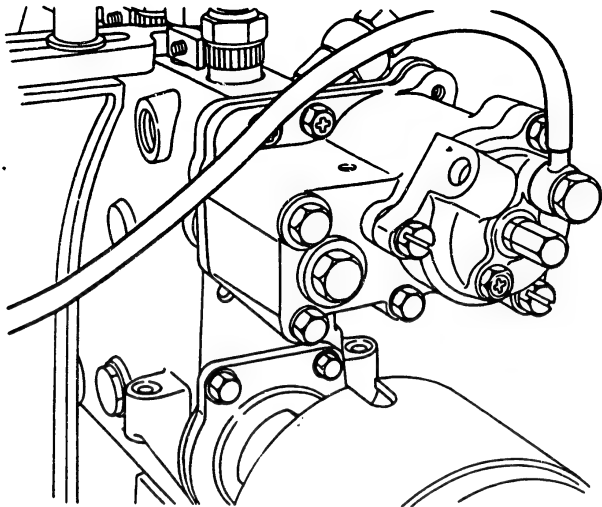

Fig. 104 Piping for the boost compensator adjustment

2. Connect the compressed-air pipe to the cover (65/18) using the eye bolt (65/27). (Fig. 104).
3. Tighten the screw (65/62) fully, then fully loosen screw (65/55).



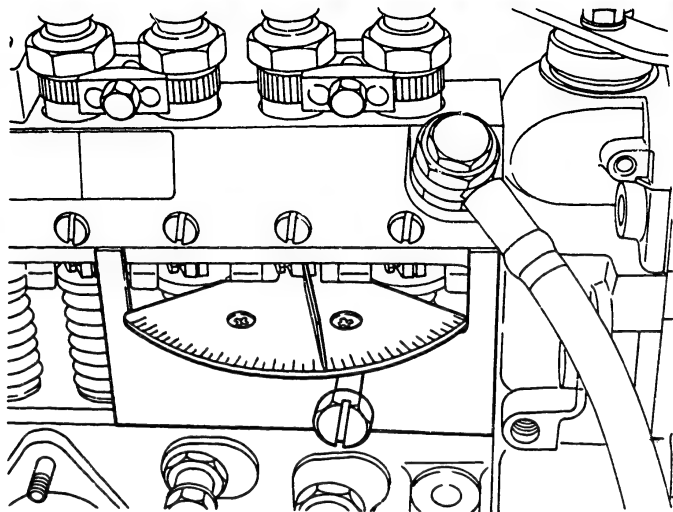
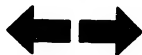

Fig. 105 Fixing the scale plate

4. Attach the measuring device (0 681 440 009) to the plunger spring chamber.
5. Fix the control lever in the "full-load" position.
6. Maintaining the pump speed at "Np" rpm, fix the measuring device scale with the indicator at control rack position "R2" mm. (Figs. 102 and 105)



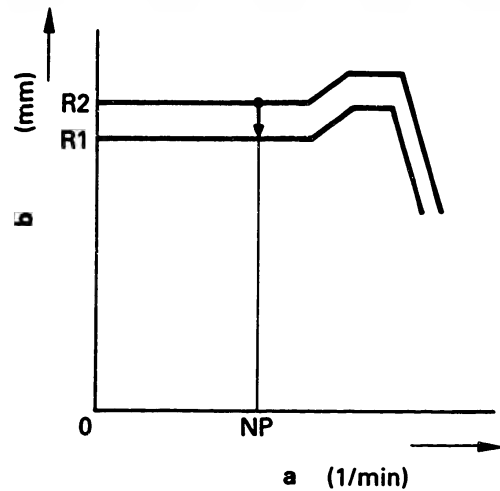

Fig. 106

a = Pump speed (rpm)
 b = Control rack position

7. Boost compensator stroke adjustment

Maintaining pump speed of "Np" rpm, shift the control rack position from "R2" mm to "R1" mm using screw (65/55) and then lock the screw with the nut (65/54). (Figs. 106 and 107)

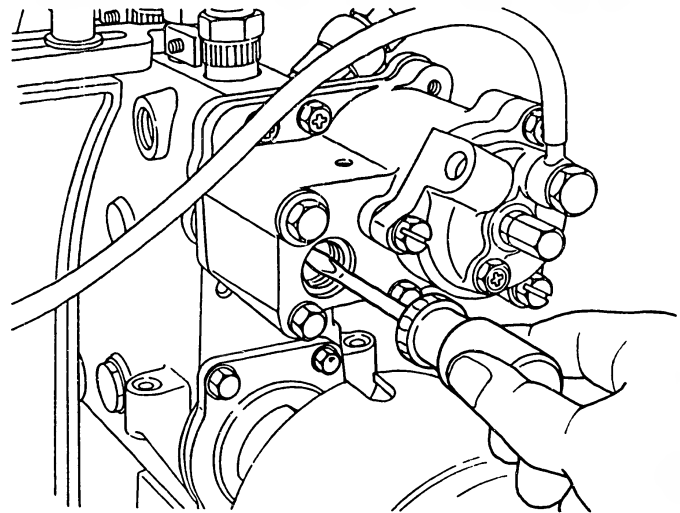
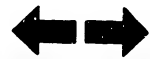

Fig. 107 Adjusting the boost compensator stroke

E22

Adjustment
 RAD-K governor



E23

Adjustment
 RAD-K governor



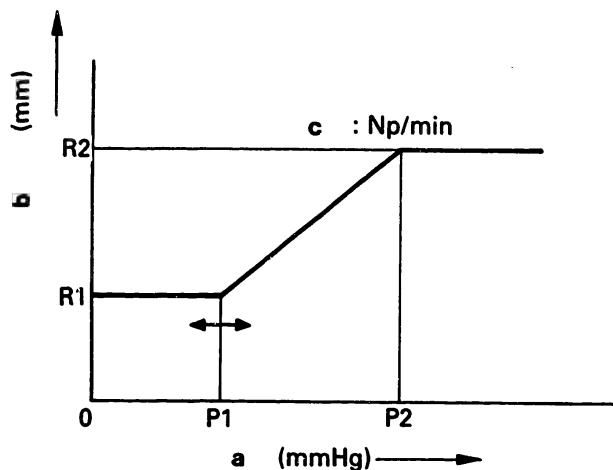

Fig. 108

a = Boost pressure
 b = Control rack position
 c = Pump speed

8. Setting the boost compensator spring force

- 1) Maintaining pump speed of "Np" rpm, loosen screw (65/62) and gradually increase the boost pressure.
- 2) Adjust the screw (65/62) so that the control rack begins moving from "R1" mm in "fuel-increase" direction when the boost pressure reaches "P1" mmHg. Then lock the screw with the nut (65/63). (Figs. 108 and 109)

Note:

At this time, control rack position "R1" mm may change.
 If so, readjust screw (65/55).

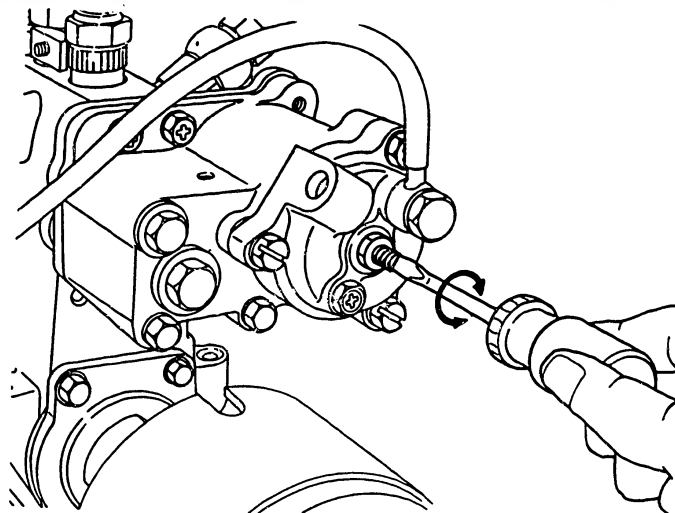

Fig. 109 Setting the boost compensator spring

E24

Adjustment
 RAD-K governor



E25

Adjustment
 RAD-K governor

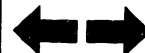

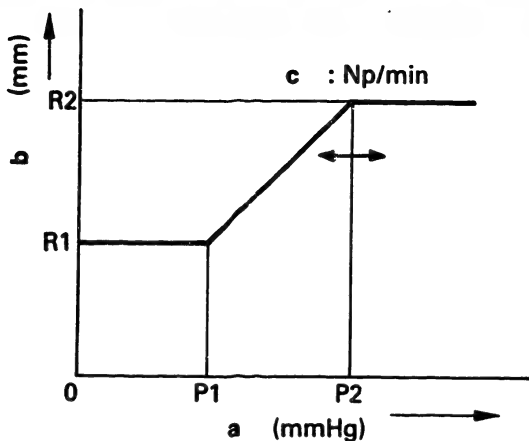

Fig. 110

- a = Boost pressure
- b = Control rack position
- c = Pump speed

- 3) Increase the boost pressure and ensure it reaches "P2" mmHg when the control rack is at "R2" mm. (Fig. 110)
 If the boost pressure fails to reach "P2" mmHg replace the spring (65/16).



OPERATING INSTRUCTIONS

Injection pump oil

Before running injection pump be sure to fill governor chamber with about 200 cc of injection pump oil.

Governor cover assembly

Do not disassemble governor cover assembly, except when replacing damaged or worn parts.

Stoppers

Each governor stopper is set on an injection pump test stand or engine test bench. Do not tamper with such settings without the aid of these facilities. Furthermore, each exposed stopper is sealed at the time of engine tests conducted by the engine manufacturer concerned.

After resetting each stopper, it must be resealed.



SPECIAL TOOLS FOR ADJUSTMENT

No.	Part No.	Tool Name	Application
1	1 688 130 130	Measuring Device	For measuring control rack travel of PE(S)-A, AD pump.
2	0 681 440 009	Measuring Device	For measuring control rack travel of PE(S)-A, AD pump. (Used for adjustment of smoke limiter and boost compensator)
3	1 688 130 183	Adjusting Device	For measuring load control lever angle of RAD-(K) governor.
4	KDEP 2605	Wrench	For adjusting torque control device travel of RAD-K governor.
5	Commercially available	Air Compressor	For adjusting boost compensator of RAD-(K) governor.

F1	Special tools for adjustment	
	RAD-K governor	

F2	Special tools for adjustment	
	RAD-K governor	

1

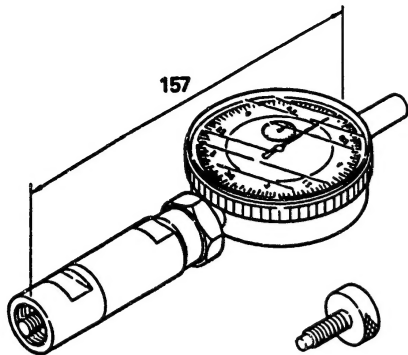

2

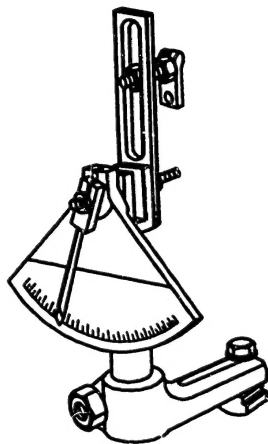
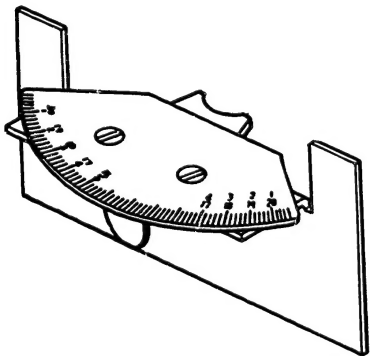

3

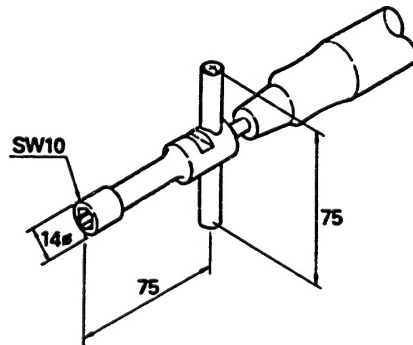

4

Fig. 111 Special tools for adjustment

1 = Measuring device

2 = Measuring device

3 = Adjusting device

4 = Wrench

F3

Special tools for adjustment
RAD-K governor



F4

Special tools for adjustment
RAD-K governor



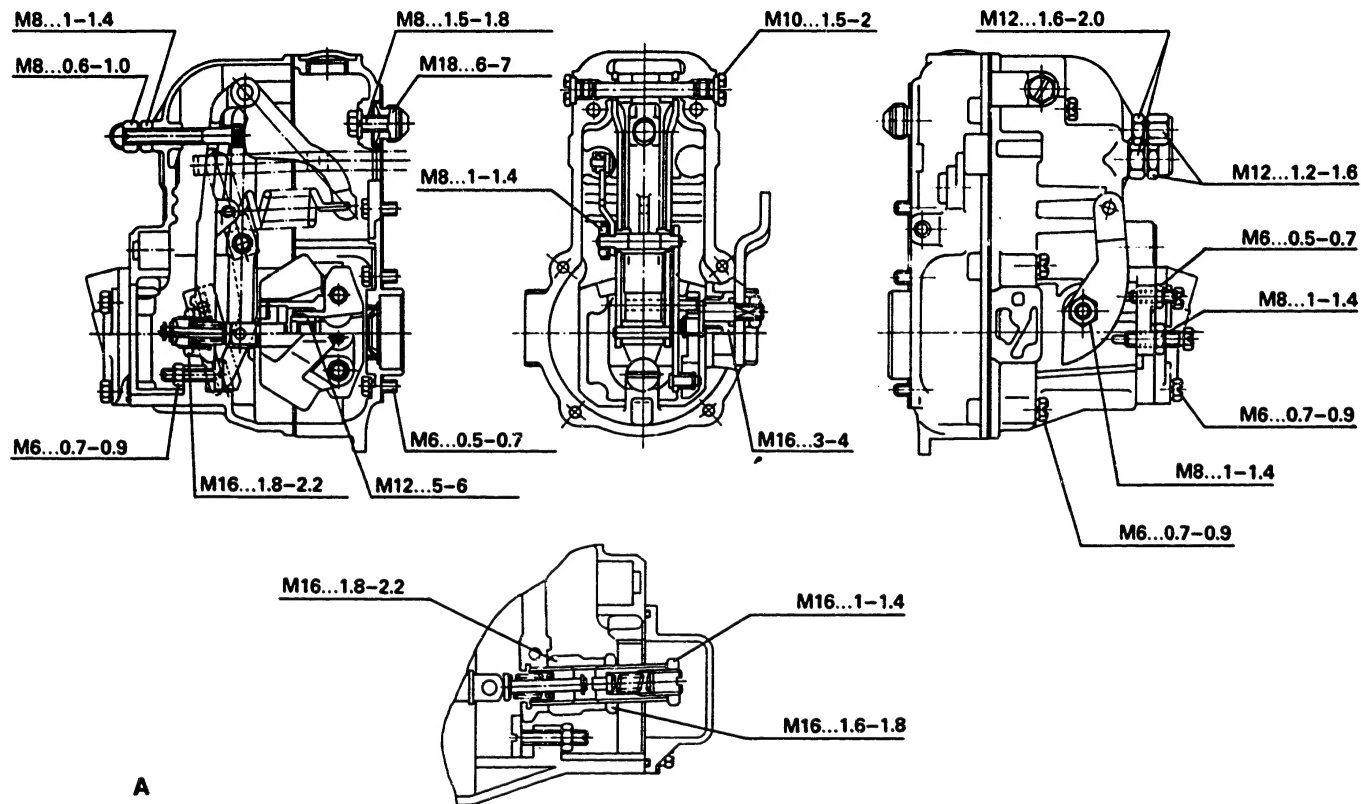

Fig. 112

A = Unit: kg-m

TIGHTENING TORQUE

F5	Tightening torque	➔
	RAD-K governor	

F6	Tightening torque	➔
	RAD-K governor	

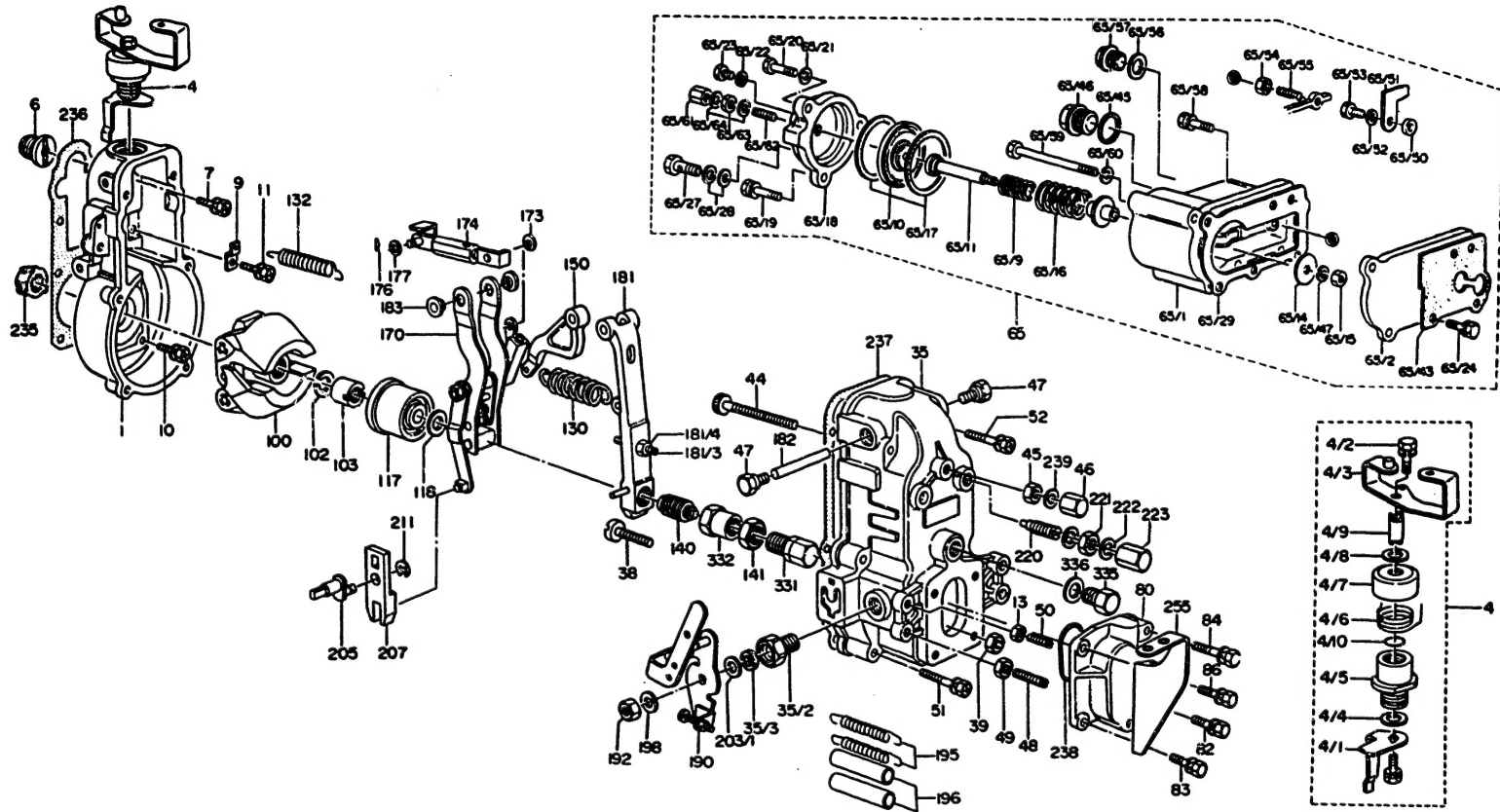

Fig. 113
 BOOST COMPENSATOR EQUIPPED
 RAD-K GOVERNOR
 EXPLODED VIEW

F7

Exploded view
 RAD-K governor



F8

Exploded view
 RAD-K governor



CONTENTS

Coordinates

FEATURES	A 2
PRINCIPLES OF OPERATION	A 3
Spring and weight	A 3
Balance between spring and centrifugal force .	A 6
Fuel injection quantity adjustment operation ...	A 8
RAD type governor	A 9
RAD-K type governor	A 13
Torque control device	A 15
CONSTRUCTION	A 17
RAD type governor	A 19
RAD-K type governor	A 21
OPERATION	A 24
RAD type governor	A 26
RAD-K type governor	B 4
DISASSEMBLY	B 12
INSPECTION	C 16
REASSEMBLY	C 25
ADJUSTMENT	D 6
OPERATING INSTRUCTIONS	E 27
SPECIAL TOOLS FOR ADJUSTMENT	F 1
TIGHTENING TORQUE	F 5
BOOST COMPENSATOR EQUIPPED RAD-K GOVERNOR EXPLODED VIEW	F 7

N28

Contents
RAD-K governor

